



ZIS393  
IL 420-1  
EDIZ. 28/01/2019

# HYPERFOR-I

**I**

**ATTUATORE ELETTROMECCANICO  
IRREVERSIBILE TRIFASE 230V CON  
INVERTER PER CANCELLI SCORREVOLI  
FINO A 4000 KG DI PESO**

**GB**

**230V THREE-PHASE  
ELECTRO-MECHANICAL IRREVERSIBLE  
ACTUATOR WITH INVERTER FOR  
SLIDING GATES UP TO 4000 KG**

**F**

**OPERATEUR ELECTROMECHANIQUE  
IRREVERSIBLE 230V TRIPHASE  
AVEC INVERSEUR POUR PORTAILS  
COULISSANTS JUSQU'À 4000 KG**

**E**

**MOTOR ELECTROMECHANICO  
IRREVERSIBLES 230V TRIFASICO CON  
INVERTER PARA PUERTAS CORREDERAS  
HASTA 4000 KG DE PESO**

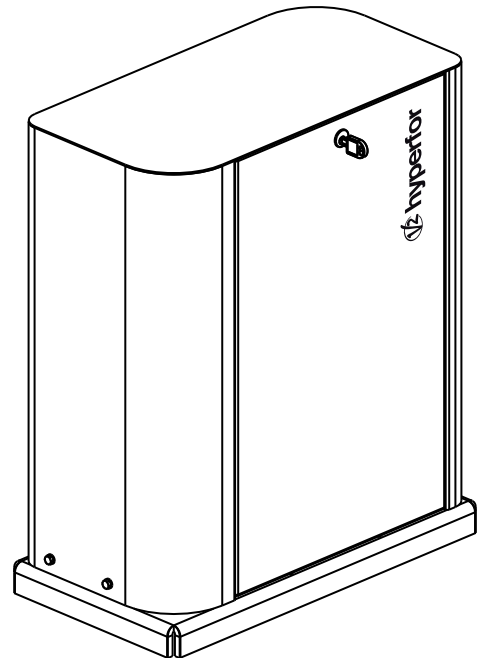

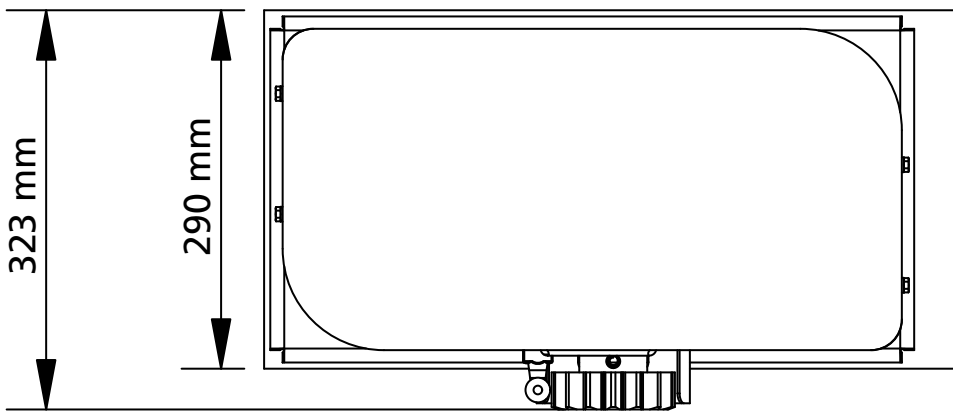
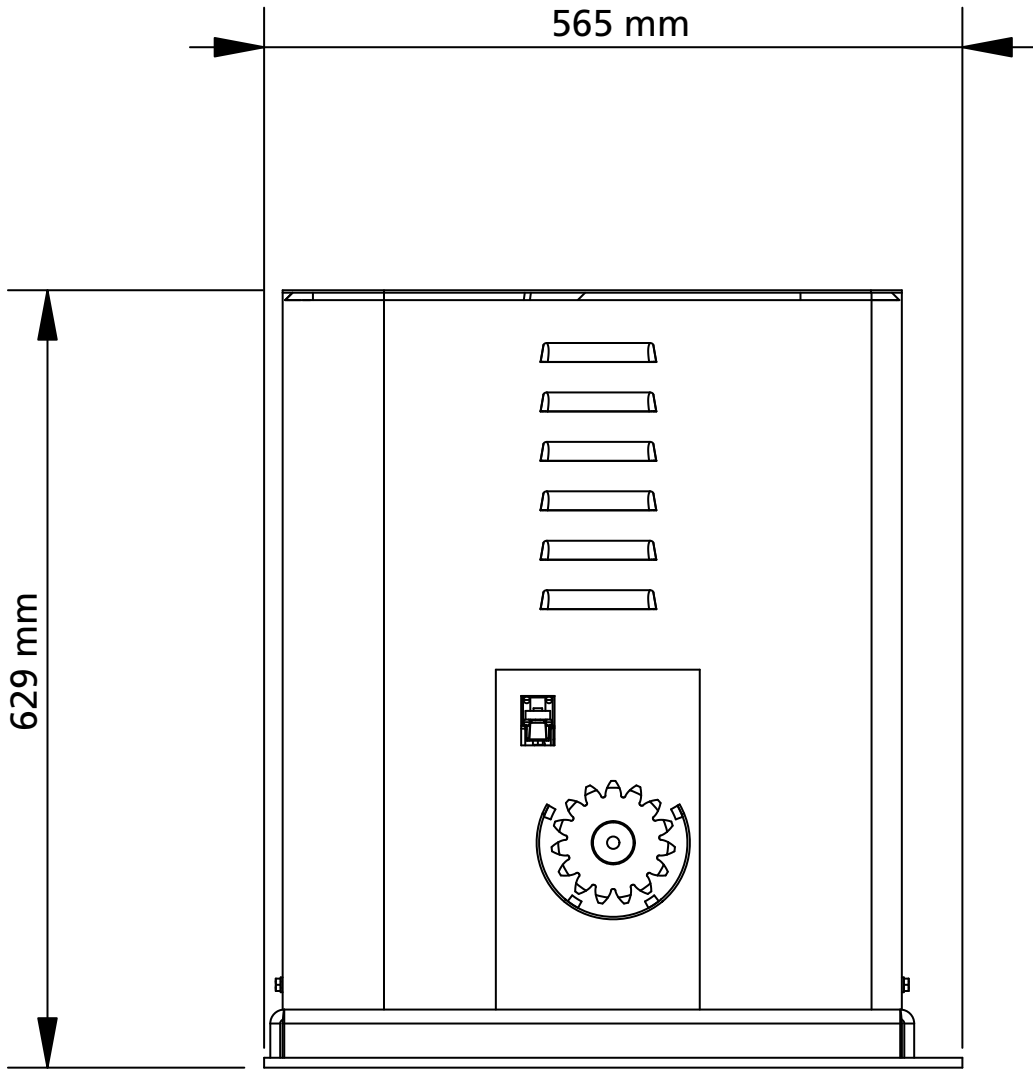

# INDEX

<b>1 - GENERAL SAFETY INFORMATION</b> .....	34
1.1 - PRELIMINARY CHECKS AND IDENTIFICATION OF THE TYPE TO BE USED.....	35
1.2 - TECHNICAL ASSISTANCE SERVICE.....	36
1.3 - EU DECLARATION OF CONFORMITY .....	36
<b>2 - TECHNICAL DATA</b> .....	36
<b>3 - INSTALLATION OF THE MOTOR</b> .....	37
3.1 - INSTALLATION OF THE MOTOR .....	37
3.2 - MOUNTING THE RACK .....	38
3.3 - FIXING OF THE MOTOR.....	38
3.4 - INSTALLING THE MAGNETIC LIMIT SWITCHES.....	39
3.5 - TORQUE LIMITER .....	39
3.6 - MOTOR OVERRIDING SYSTEM .....	40
3.7 - INSTALLATION LAYOUT .....	40
<b>4 - DESCRIPTION OF THE CONTROL UNIT</b> .....	41
<b>5 - LANGUAGE SELECTION</b> .....	41
<b>6 - CONTROL PANEL</b> .....	41
<b>7 - ELECTRIC CONNECTIONS</b> .....	42
<b>8 - POWER SUPPLY</b> .....	44
<b>9 - OPERATION OF THE MOTOR</b> .....	44
<b>10 - EMERGENCY STOP</b> .....	45
<b>11 - PHOTOCELLS</b> .....	46
11.1 - POWER OF PHOTOCELLS AND AND FUNCTIONAL TEST.....	46
<b>12 - DETECTION OF OBSTACLES (AMPEROMETRIC SENSOR, ENCODER, SAFETY RIBBONS)</b> .....	48
12.1 - AMPEROMETRIC SENSOR.....	48
12.2 - SAFETY RIBBONS .....	48
<b>13 - BLINKER</b> .....	49
<b>14 - OPEN GATE WARNING LIGHT</b> .....	49
<b>15 - EXTERNAL ANTENNA</b> .....	49
<b>16 - CONTROL MODE FROM TERMINAL BOARD</b> .....	50
<b>17 - REMOTE CONTROL MODE</b> .....	51
<b>18 - OPERATING MODES</b> .....	51
<b>19 - SPECIAL OPERATING MODES</b> .....	51
<b>20 - OPTION RELAY OUTPUT</b> .....	52
20.1 - COURTESY LIGHT .....	52
20.2 - LOCK.....	52
20.3 - SERVICE REPORTING .....	53
20.4 - OPENING COMMAND.....	53
20.5 - CLOSING COMMAND.....	53
20.6 - SAFETY DEVICE TESTS.....	53
20.7 - CUSTOM .....	53
<b>21 - ADI INTERFACE</b> .....	53
<b>22 - PROGRAMMING</b> .....	54
22.1 - ACCESS TO MAIN PROGRAMMING MENUS.....	54
22.2 - LOADING DEFAULT PARAMETERS.....	54
22.3 - TRAVEL LEARNING .....	54
22.4 - READING THE CYCLE COUNTER.....	55
22.5 - PROGRAMMING THE OPERATING PARAMETERS .....	55
22.6 - TABLE OF PROGRAMMING PARAMETERS.....	56
<b>23 - OPERATION DEFECTS</b> .....	61
<b>24 - TESTING AND START-UP</b> .....	62
<b>25 - MAINTENANCE</b> .....	62
<b>26 - DISPOSAL OF THE PRODUCT</b> .....	62

# AUTOMATION DEVICE INSTALLERS MANUAL

## 1 - GENERAL SAFETY INFORMATION



**Prior to proceeding with installation, it is essential the instructions be read in full, since they contain important information regarding safety, installation, use and maintenance.**

AUTOMATION MUST BE IMPLEMENTED IN COMPLIANCE WITH THE EUROPEAN REGULATIONS IN FORCE:

**EN 60204-1, EN 12445, EN 12453, EN 13241-1, EN 12635**

- The installer must provide for a device (es. magnetothermal switch) ensuring the omnipolar sectioning of the equipment from the power supply. The standards require a separation of the contacts of at least 3 mm in each pole (EN 60335-1).
- The plastic case has an IP44 insulation; to connect flexible or rigid pipes, use pipefittings having the same insulation level.
- Installation requires mechanical and electrical skills, therefore it shall be carried out by qualified personnel only, who can issue the Compliance Certificate concerning the whole installation (Machine Directive 2006/42/CEE, Annex IIA).
- Also the automation upstream electric system shall comply with the laws and rules in force and be carried out workmanlike.
- We recommend to make use of an emergency button, to be installed by the automation (connected to the control unit STOP input) so that the gate may be immediately stopped in case of danger.
- For correct installation of the system, we recommend following the instructions issued by UNAC very carefully.
- This instruction manual is only for qualified technicians, who specialize in installations and automations.
- The contents of this instruction manual do not concern the end user.
- Every programming and/or every maintenance service should be done only by qualified technicians.
- Anything not expressly described in these instructions is prohibited; unforeseen uses may be a source of danger to people and property.
- Do not install the product in explosive environments and atmospheres: the presence of inflammable gases or fumes is a serious safety hazard.
- Do not make any modifications to any part of the automation device, or the accessories connected to it, unless described in this manual.
- Any other modifications will void the warranty on the product.
- The installation steps should be conducted so as to avoid rainy weather, which can expose electronic circuits to dangerous water seepage.
- All operations requiring the casing of the device to be opened should be performed with the control unit disconnected from the electricity supply and with a warning notice displayed, for example: "CAUTION, MAINTENANCE IN PROGRESS".
- Avoid exposing the device close to sources of heat and flame.

- In the event of interventions on automatic or differential breakers or fuses, it is essential that faults be identified and resolved prior to resetting. In the case of faults that cannot be resolved using the information to be found in this manual, consult the V2 customer assistance service.
- V2 declines all responsibility for failure to comply with good construction practice standards in addition to structural deformation of the gate that might occur during use.
- V2 reserves the right to make modifications to the product without prior warning.
- Installation/maintenance personnel should wear individual protection devices (IPDs), such as overalls, safety helmets, boots and gloves.
- The ambient operating temperature should be that indicated in the technical characteristics table.
- The automation device should be shut down immediately in the event of any anomalous or hazardous situation; the fault or malfunction should be immediately reported to the person responsible.
- All safety and hazard warnings on the machinery and equipment should be complied with.
- Electromechanical actuators for gates are not intended to be used by people (including children) with diminished physical, sensory or mental capacity, or lacking in experience or knowledge, unless they are under supervision or have been instructed in use of the actuator by a person responsible for safety.

**V2 has the right to modify the product without previous notice; it also declines any responsibility to damage or injury to people or things caused by improper use or wrong installation.**

## 1.1 - PRELIMINARY CHECKS AND IDENTIFICATION OF THE TYPE TO BE USED

The automation device should not be used until installation, as specified in "Testing and start-up", has been performed. It should be remembered that the device does not compensate for defects caused by improper installation, or poor maintenance, thus, prior to proceeding with installation, ensure that the structure is suitable and meets current standards and, if necessary, perform any structural modifications aimed at the implementation of safety gaps and the protection or segregation of all crushing, shearing and transit zones, and verify that:

- The gate has no friction points, either during closing or opening.
- The gate is well balanced, i.e. there is no tendency to move spontaneously when stopped in any position.
- The position identified for fixing the motor reducer allows easy and safe manual manoeuvring, compatible with the size of the motor reducer itself.
- The support on which the automation device will be fixed is solid and durable.
- The mains power supply to which the automation device is connected has a dedicated safety earthing system and differential breaker with tripping current less than or equal to 30 mA (the breaker gap distance should be greater than or equal to 3 mm).

**Warning: The minimum safety level depends on the type of use; please refer to the following outline:**

TYPE OF ACTIVATION COMMANDS	CLOSURE USE TYPE		
	GROUP 1 Informed people (use in private area)	GROUP 2 Informed people (use in public area)	GROUP 3 Informed people (unlimited use)
Man-present command	A	B	Not possible
Remote control and closure in view (e.g. infrared)	C or E	C or E	C and D or E
Remote control and closure not in view (e.g. radio)	C or E	C and D or E	C and D or E
Automatic control (e.g. timed closure control)	C and D or E	C and D or E	C and D or E

**GROUP 1** - Only a limited number of people are authorised for use, and closure is not in a public area. Examples of this type are gates inside business premises, where the sole users are employees, or a part of them who have been suitably informed.

**GROUP 2** - Only a limited number of people are authorised for use, but in this case, closure is in a public area. An example of this may be a company gate that accesses onto a public street, and which is only used by employees.

**GROUP 3** - Anyone can use the automated closure, which is thus located on public land. For example the access gate to a supermarket or an office, or a hospital.

**PROTECTION A** - Closure is activated by means of a control button with the person present, i.e. with maintained action.

**PROTECTION B** - With the person present, closure is activated by a command controlled by means of a key-switch or the like, in order to prevent use by unauthorised persons.

**PROTECTION C** - Restricts the force of the leaf of the door or gate. I.e., in the case of the gate striking an obstacle, the impact force must fall within a curve established by the regulations.

**PROTECTION D** - Devices, such as photocells, capable of detecting the presence of people or obstacles. They may be active on just one side or on both sides of the door or gate.

**PROTECTION E** - Sensitive devices, such as footboards or immaterial barriers, capable of detecting the presence of a person, and installed in such a way that the latter cannot be struck in any way by a moving leaf or panel. These devices should be active within the entire "danger zone" of the gate. The Machinery Directive defines "Danger Zone" as any zone surrounding and/or near machinery where the presence of an exposed person constitutes a risk to the health and safety of that person.

**The risk analysis should take into consideration all danger zones for the automation device, which should be appropriately protected and marked.**

**In a clearly visible area, apply a sign with information identifying the motorised door or gate.**

**The installer should provide the user with all the information relating to automatic operation, emergency opening and maintenance of the motorised door or gate.**

## 1.2 - TECHNICAL ASSISTANCE SERVICE

For any installation problem please contact our Customer Service at the number +39-0172.812411 operating Monday to Friday from 8:30 to 12:30 and from 14:00 to 18:00.

## 1.3 - EU DECLARATION OF CONFORMITY AND DECLARATION OF INCORPORATION OF PARTLY COMPLETED MACHINE

**Declaration in accordance with Directives: 2014/35/UE (LVD); 2014/30/UE (EMC); 2006/42/CE (MD) ANNEX II, PART B**

The manufacturer V2 S.p.A., headquarters in Corso Principi di Piemonte 65, 12035, Racconigi (CN), Italy

Under its sole responsibility hereby declares that:  
the partly completed machinery model(s):  
HYPERFOR 4000-I  
HYPERFOR 4000-I-M4

Description: electromechanical actuator for sliding gates

- is intended to be installed on sliding gates, to create a machine according to the provisions of the Directive 2006/42/EC. The machinery must not be put into service until the final machinery into which it has to be incorporated has been declared in conformity with the provisions of the Directive 2006/42/EC (annex II-A).
- is compliant with the applicable essential safety requirements of the following Directives:  
Machinery Directive 2006/42/EC (annex I, chapter 1)  
Low Voltage Directive 2014/35/EU  
Electromagnetic Compatibility Directive 2014/30/EU  
Directive ROHS2 2011/65/CE

The relevant technical documentation is available at the national authorities' request after justifiable request to:  
V2 S.p.A.  
Corso Principi di Piemonte 65, 12035, Racconigi (CN), Italy

The person empowered to draw up the declaration and to provide the technical documentation:

**Antonio Livio Costamagna**  
Legal representative of V2 S.p.A.  
Racconigi, il 01/06/2015



## 2 - TECHNICAL DATA

	<b>HYPERFOR 4000-I</b>	<b>HYPERFOR 4000-I-M4</b>
Gate maximum weight	4000 Kg	4000 Kg
Power supply	230VAC / 50Hz	230VAC / 50Hz
Maximum power	1100 W	1100 W
Full load current	5 A	5 A
Gate maximum speed	0.16 ÷ 0,32 m/s	0.16 ÷ 0,32 m/s
Maximum thrust	4800 N	4800 N
Duty cycle	50%	50%
Pinion	M6 - Z15	M4 - Z16
Operation temperature	-20°C ÷ +55°C	-20°C ÷ +55°C
Weight	80 Kg	80 Kg
Protection	IP55	IP55
Maximum load on 24 VAC attachments	10W	10W
Protection fuses	F1 = T320mA F2 = F10A	F1 = T320mA F2 = F10A

## 3 - INSTALLATION OF THE MOTOR

### 3.1 - POSITIONING OF THE MOTOR

To fix HYPERFOR, follow the instructions below:

1. use the measurements indicated in the drawing for the foundations
2. Arrange for one or two pipes for the passage of electric cables
3. Assemble the 4 clamps on the anchoring plate and fix them with the 4 bolts issued with the motor
4. Pour the concrete and position the anchoring plate

**⚠ WARNING: check that the plate be on a perfectly levelled surface and parallel to the gate**

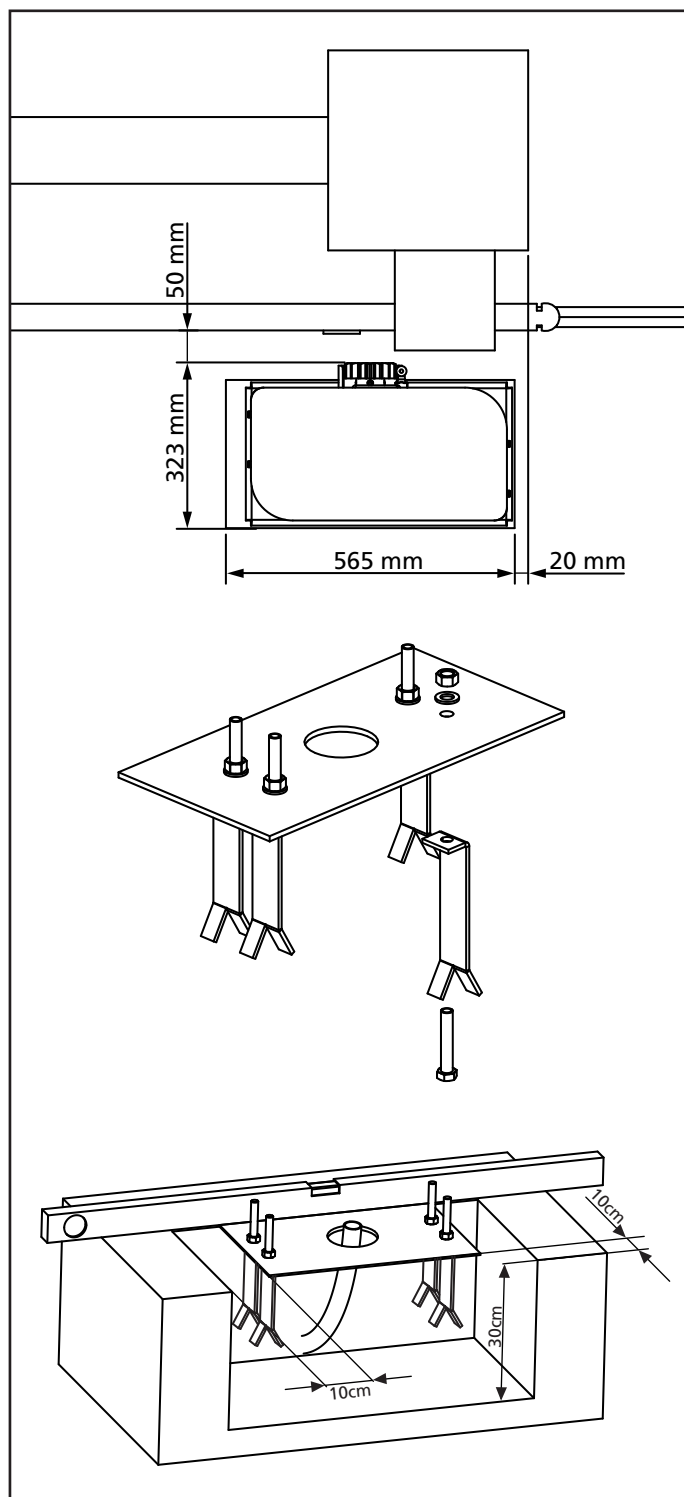

5. Wait for the complete setting of the concrete
6. Unscrew the bolts fixing the base to the clamps and put the motor on the plate
7. Adjust the 4 grains **F** to make the motor be perfectly levelled
8. Control that the motor is perfectly parallel to the gate, then insert the 4 washers **R** and lightly screw the 4 bolts **D**

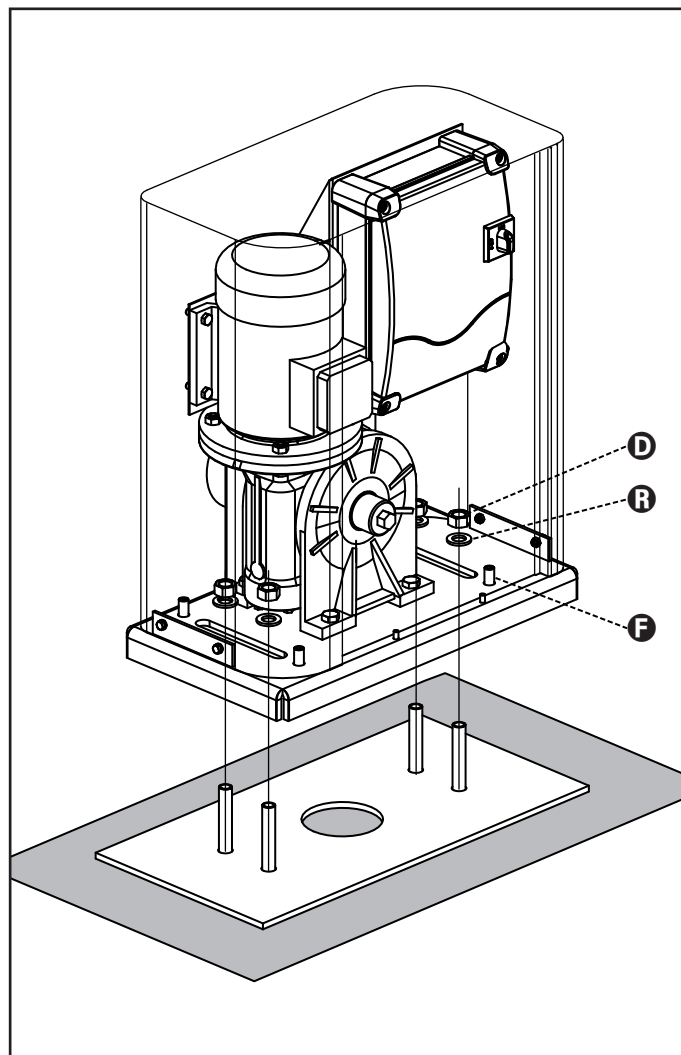

### 3.2 - MOUNTING THE RACK

1. Release the motor and turn the gate completely open.
2. Fix all the rack elements to the gate, making sure that they stand at the same height than the motor pinion.

The rack **MUST BE** positioned 1 or 2 mm over the pinion of the motor all the gate length.

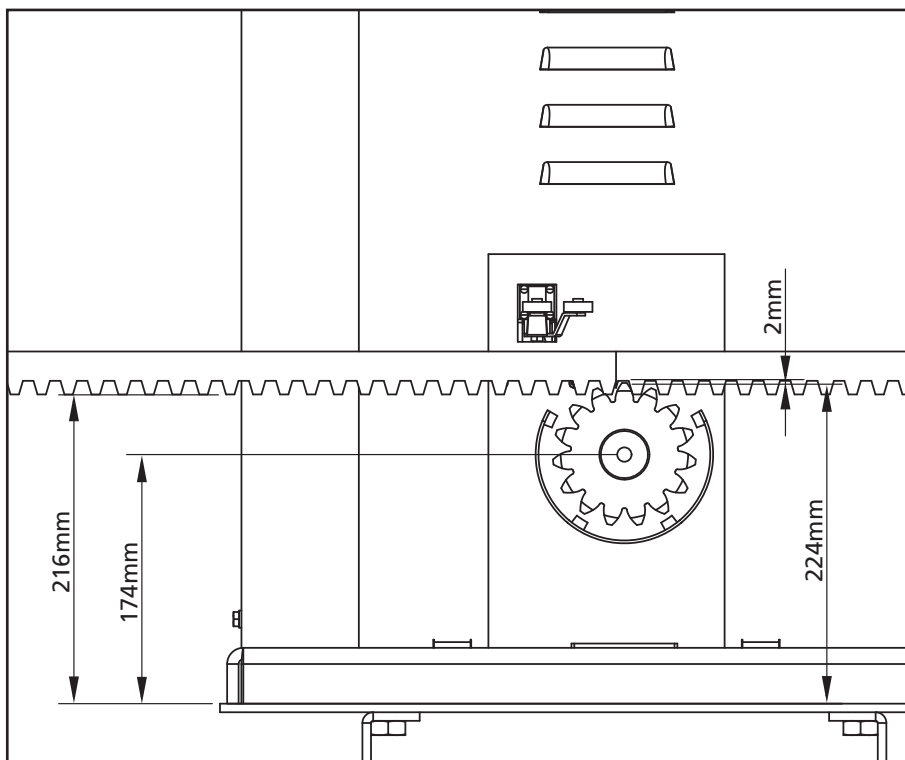

### 3.3 - FIXING OF THE MOTOR

Check the following points:

1. the motor must be on a levelled surface and perfectly parallel to the gate
2. the distance between pinion and rack must be 1 or 2 mm. If needed, adjust the 4 grains
3. the rack must be trued up with the pinion of the motor
4. the minimum distance between the maximum overall of the gate and the case of the pinion of the motor must be of at least 5 mm
5. Check the above indicated conditions and proceed fixing the 4 bolts **D** anchoring the motor to the plate.

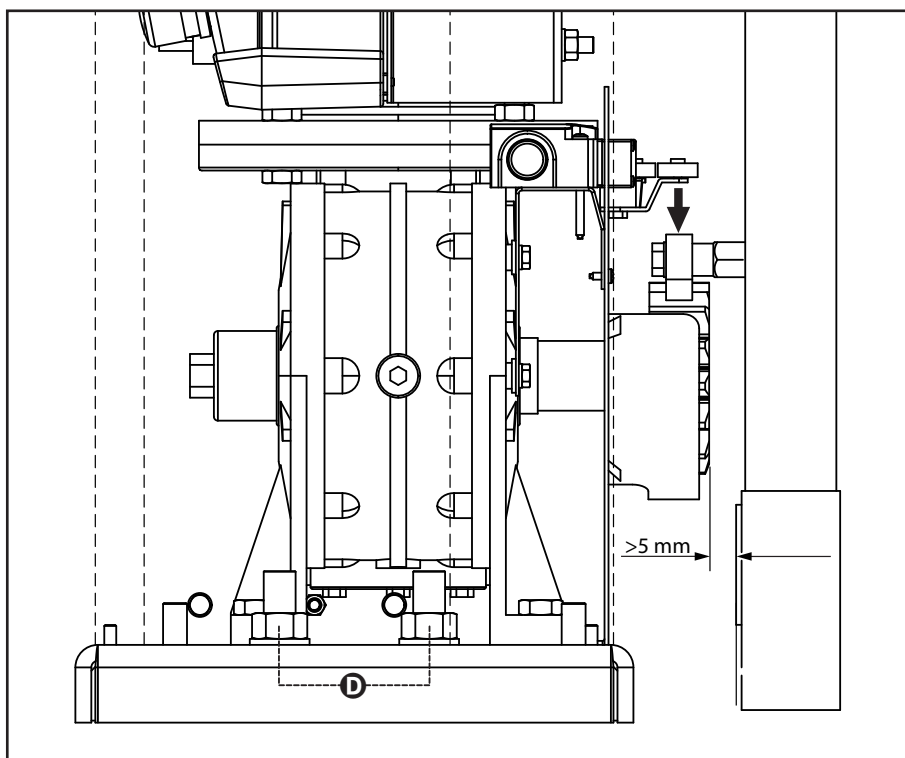



### 3.4 - INSTALLING THE MECHANICAL LIMIT SWITCHES

Install limit switches on the rack and fix them using the screws provided in the tool kit.

**⚠ ATTENTION:** check that the limit switch bracket will work effectively on the limit switch spring of the motor. If necessary add thickness between the lower part of the rack and the limit switch bracket in order to keep to the measurement as stated in the figure.

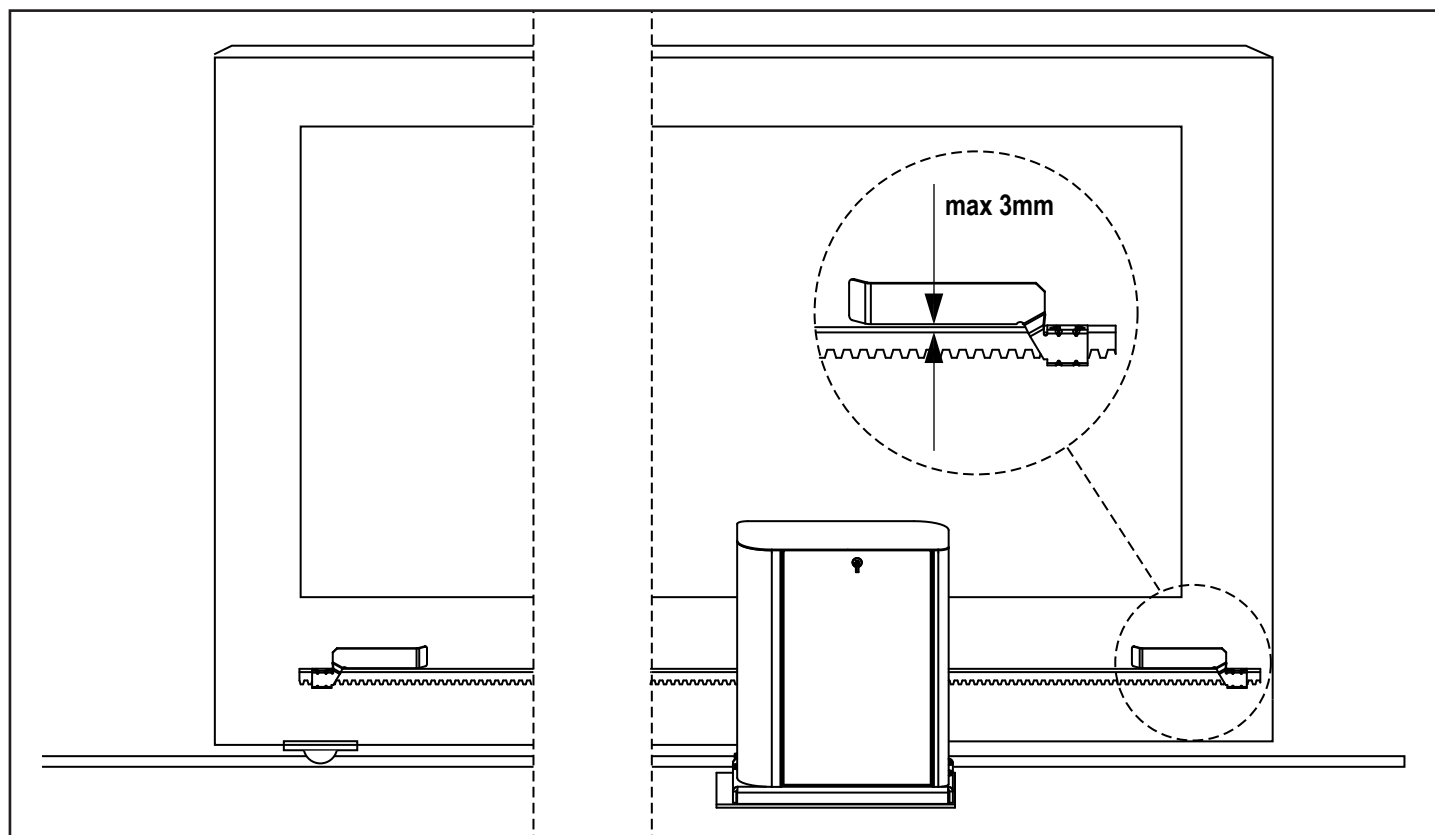

### 3.5 - TORQUE LIMITER

To adjust the motor torque, follow the instructions below:

1. Open the rear door
2. Unscrew and remove screw **L** with the supplied 4" Allen wrench
3. Screw clockwise (left thread) the ring nut **K** using the supplied 19" wrench until removal is complete
4. In order to set the motor torque, operate the self-locking nut **M** with a 27 wrench:
  - screw by half turn nut **M** to increase the torque; operate the motor to verify if the torque is the desired one; if necessary, screw again nut **M** until the desired value is reached
  - unscrew by half turn nut **M** to decrease the torque; operate the motor to verify if the torque is the desired one; if necessary, unscrew again nut **M** until the desired value is reached
5. After the adjustment is completed, screw anti-clockwise (left thread) the ring nut **K** up to thread end.  
**NOTE: if you overtighten the ring nut the motor is released**
6. Fully screw screw **L**
7. Close the rear door

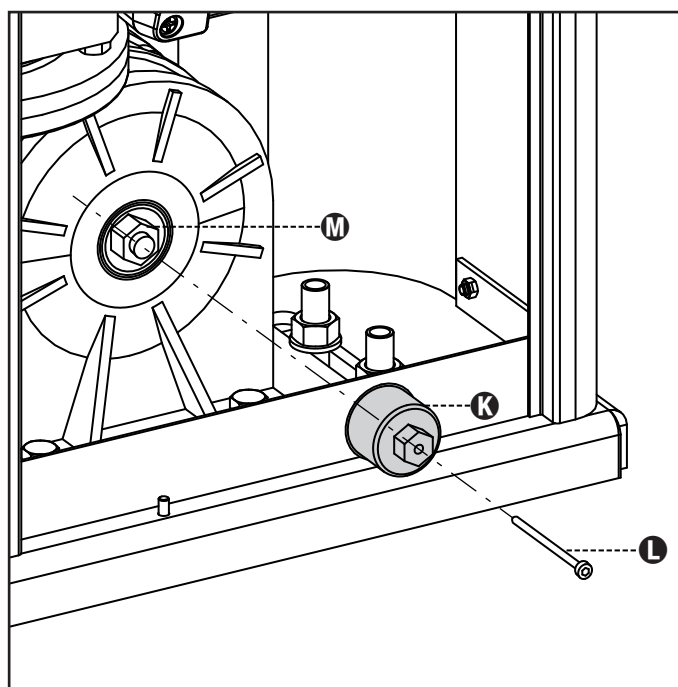

### 3.6 - MOTOR OVERRIDING SYSTEM

In the absence of power, the gate can be released by operating on the motor:

1. Open the rear hatch
2. Screw anti-clockwise (left thread) the ring nut **K** using the supplied 19" wrench until the pinion is released

To restart the automation proceed as follows:

1. Screw clockwise (left thread) the ring nut **K** up to the limit given by screw **L**
2. Close the rear hatch

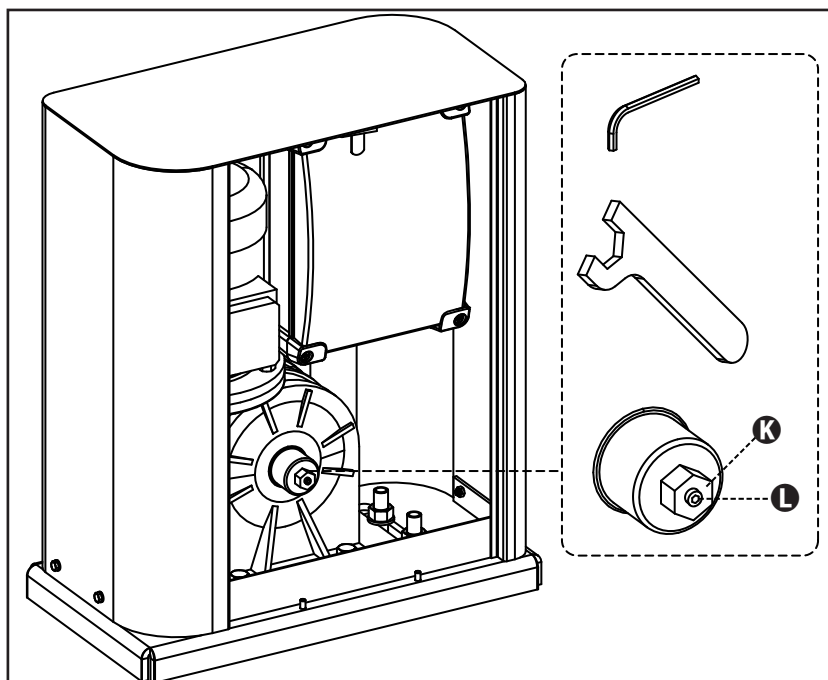

### 3.7 - INSTALLATION LAYOUT

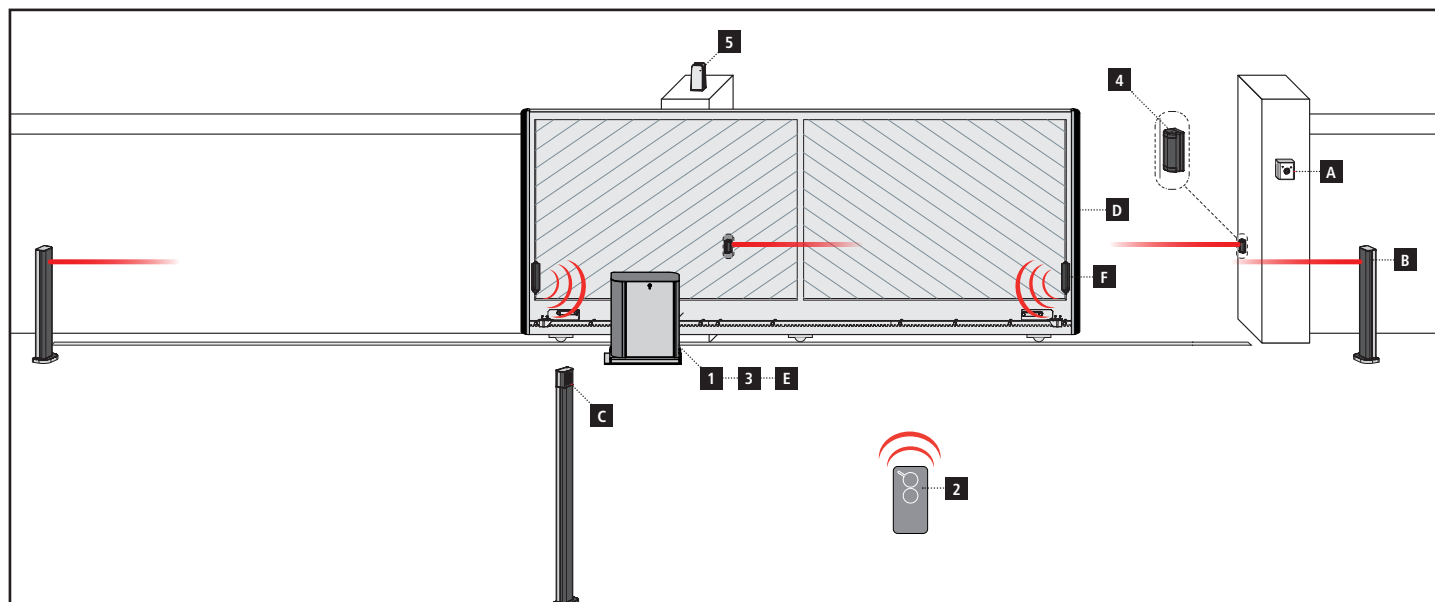

#### COMPONENTS

- 1 Motor
- 2 Transmitter
- 3 Receiving module
- 4 Photocells
- 5 Flashing light

#### ADDITIONAL ACCESSORIES

- A Key switch
- B Pillar photocells
- C Pillar-mounted digital radio switch
- D Safety edges
- E WES-ADI module (via radio management of edges)
- F WES sensors

LENGTH OF THE CABLE	< 10 metres	from 10 to 20 metres	from 20 to 30 metres
Power supply 230V	3G x 1,5 mm <sup>2</sup>	3G x 1,5 mm <sup>2</sup>	3G x 2,5 mm <sup>2</sup>
Photocells (TX)	2 x 0,5 mm <sup>2</sup>	2 x 0,5 mm <sup>2</sup>	2 x 0,5 mm <sup>2</sup>
Key switch	4 x 0,5 mm <sup>2</sup>	4 x 0,5 mm <sup>2</sup>	4 x 0,5 mm <sup>2</sup>
Photocells (RX)	2 x 0,5 mm <sup>2</sup>	2 x 0,5 mm <sup>2</sup>	2 x 0,5 mm <sup>2</sup>
Flashing light	2 x 1,5 mm <sup>2</sup>	2 x 1,5 mm <sup>2</sup>	2 x 1,5 mm <sup>2</sup>
Antenna (integrated into the flashing light)	RG174	RG174	RG174



## 7 - ELECTRIC CONNECTIONS

TOP BOARD	
<b>A1</b>	Antenna shielding
<b>A2</b>	Antenna
<b>S1</b>	ING1 - configurable input to connect devices with N.O. contact
	ING1 parameter DEFAULT = <b>START</b> (activates the cycle)
<b>S2</b>	ING2 - configurable input to connect devices with N.O. contact
	ING2 parameter DEFAULT = <b>ST.PE</b> (partial opening)
<b>S3</b>	ING3 - configurable input to connect conventional devices with N.O. contact
	ING3 parameter DEFAULT = <b>NO</b> (no function)
<b>S4</b>	Common (-)
<b>S5</b>	Photocell 1. N.C. contact
	FOT1 parameter DEFAULT = <b>NO</b> (no function)
<b>S6</b>	Photocell 2. N.C. contact
	FOT2 parameter DEFAULT = <b>CFCH</b> (enabled when closing and with closed gate)
<b>S7</b>	Safety ribb. 1. N.C. contact
	COS1 parameter DEFAULT = <b>NO</b> (no function)
<b>S8</b>	Safety ribb. N.C. contact
	COS2 parameter DEFAULT = <b>NO</b> (no function)
<b>S9</b>	Common (-)
<b>H1</b>	Closing limit switch. N.C. contact (PRE-WIRED)
<b>H2</b>	Opening limit switch. N.C. contact (PRE-WIRED)
<b>H3 - H4</b>	NOT USED
<b>H5</b>	Common (-)
<b>H6*</b>	- Open gate warning light - 24Vdc blinker
	SPIA parameter DEFAULT = <b>W.L.</b> (open gate warning light)
<b>H7</b>	- Common open gate warning light - 12Vdc common power supply
<b>H8</b>	12Vdc power supply
<b>E1 / E2</b>	24Vac accessory power supply
<b>E3 / E4</b>	Common accessories power supply
<b>E5</b>	Photocell TX power supply (24Vac) for Functional test
<b>T1 - T2</b>	Emergency STOP

LOWER BOARD	
<b>MOTOR U3-U2-U1</b>	Motor (PRE-WIRED)
<b>B2-B1</b>	REL3 relay options (16A - 230V)
	Parameter REL3 DEFAULT = <b>NO</b> (no function)
<b>OUTPUT Z6-Z5</b>	REL2 relay options (5A - 230V)
	Parameter REL2 DEFAULT = <b>NO</b> (no function)
<b>OUTPUT Z4-Z3</b>	REL1 relay options (5A - 230V)
	Parameter REL1 DEFAULT = <b>LUCI</b> (courtesy lights)
<b>OUTPUT Z2-Z1</b>	230V - 40W blinker
<b>N - L</b>	230V - 50Hz power supply network
 <b>G1 - G2</b>	Ground terminal for connection of the ground system and the motor

OTHER	
<b>F1</b>	T320mA. Power supply fuse
<b>F2</b>	F10A. Motor inverter fuse
<b>ADI</b>	ADI interface
<b>RECEIVER</b>	MR receiving modules
<b>OVERLOAD</b>	It indicates a 24Vac power overload of accessories
<b>POWER LOGIC</b>	It indicates that the control unit is powered
<b>POWER MOTOR</b>	It indicates the inverter driving the motor is powered
<b>OK</b>	GREEN LED <u>Flashes</u> when the inverter driving the motor is in stand-by <u>Turned on</u> and fixed when the motor is running
<b>ATTENTION</b>	YELLOW LED <u>Flashes</u> when the power supply of the inverter driving the motor is charging <u>Turned on</u> and fixed when the emergency STOP is on
<b>ERROR</b>	RED LED <u>Turned on</u> and fixed when a fault of the encoder is detected

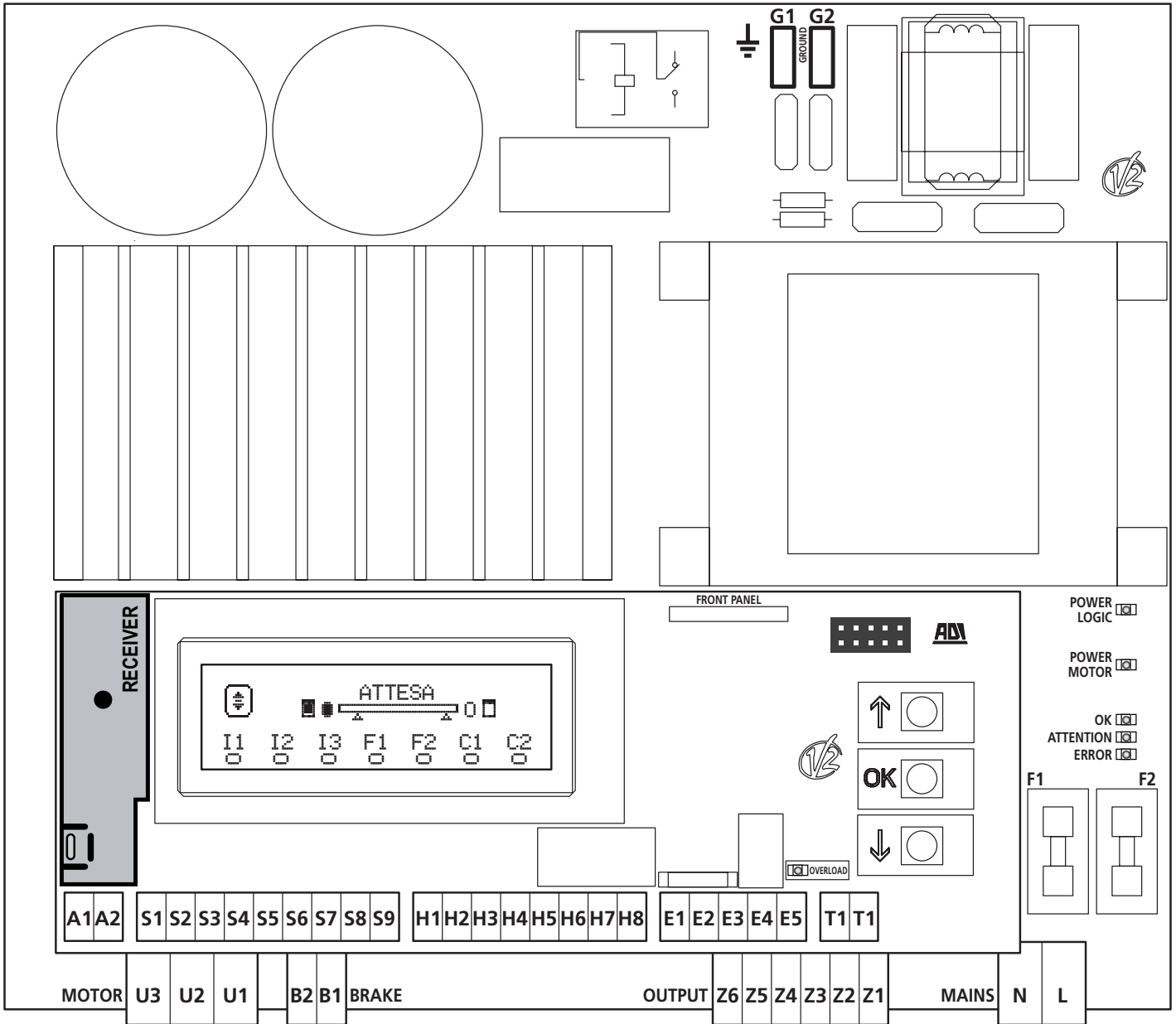

\* **H6** : H6 terminal can be used for connecting a gate open warning light or a blinker to 24Vdc.  
 Configure the **SPIA** parameter depending on the device connected

**⚠ WARNING:** The installation of the unit, safety devices and accessories must be carried out when the power supply is disconnected.

**⚠ WARNING:** connect the grounding system to the ground terminal G1-G2

## 8 - POWER SUPPLY

The control unit must be fed by a 230V - 50Hz electric line, protected by a differential magnetothermal switch complying with the law provisions in force.

Connect power supply cables to terminals **L** and **N** of the control unit.

Connect the grounding system to one of the two ground terminals **G1** and **G2**.

## 9 - OPERATION OF THE MOTOR

The operating speed of the motor can be set with different values, depending on the various stages of the opening cycle.

Each opening cycle of the gate consists of 5 stages:

### 1. Acceleration ramp

The speed of the gate gradually increases from the minimum speed (5Hz) up to the operating one (value set in the parameter **VEL**).

The time required to reach the normal operating speed is determined by the length of the acceleration ramp (**ACCEL** parameter).

The setting of the value to 0 will result in a short ramp and then the acceleration will be maximum, the setting of the value to 6 will result in a long ramp and then the acceleration will be minimal.

During this phase, the power can be increased up to 30% for more acceleration through the **SPUN** parameter

### 2. Regular operating speed

At the end of the acceleration ramp, the gate moves at the speed set in the parameter **VEL** up to the beginning of the slowdown phase.

In this phase, the motor is driven at 100% of its power. The power supplied to the motor can be decreased by the parameter **POT**.

### 3. Slowdown

- During the opening phase, the slowdown starts when the gate reaches the final part of the opening: this final part is determined by a percentage of the total opening and is set using the parameter **RAL.A**
- During the closing phase, the slowdown starts when the gate reaches the final part of the closing: this final part is determined by a percentage of the total closing and is set using the parameter **RAL.C**

When the slowdown starting point is reached, the control unit gradually decreases the motor speed up to the value set in the parameter **VEL.F**

### 4. Slowing ramp

Once the limit switch is reached, the speed of the gate is gradually brought to zero. The duration of the slowing ramp can be set with the parameter **DECEL**

### 5. Braking

When the motor speed reaches zero, the switch sends a brake command on the motor phases to ensure that the motor actually stops.

The intensity of the braking can be set using the parameter **FREN0**

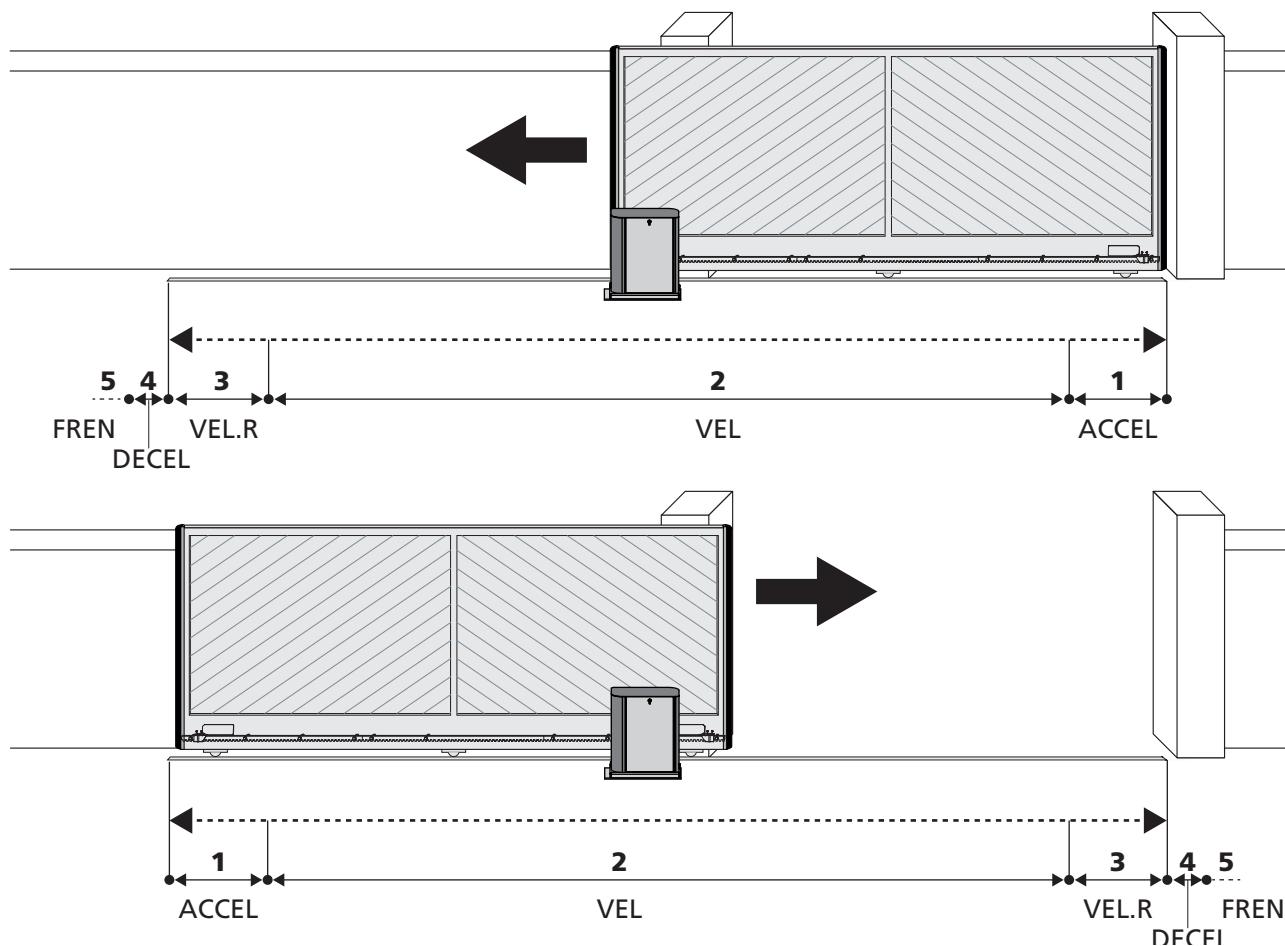

## 10 - EMERGENCY STOP

For added security it is **OBLIGATORY** to install a STOP switch that when pressed will immediately block automation.  
The switch must have a normally closed contact, which opens in case of activation.

**NOTE:** terminals **T1** and **T2** are connected to allow start of automation before connecting the STOP switch.

Connect the cables of the STOP switch between terminals **T1** and **T2** of the unit.

**⚠ CAUTION: if the STOP input is not used, the terminals T1 and T2 must be bridged.**

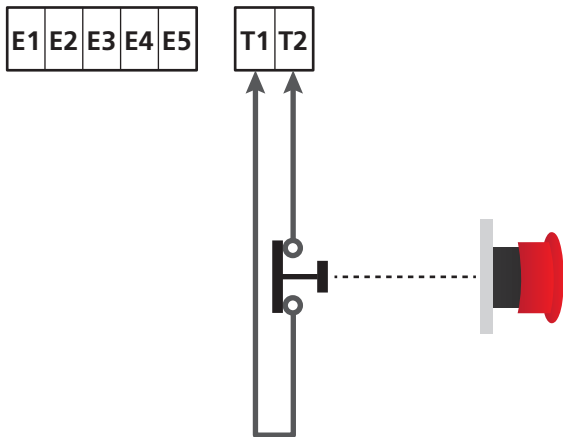

## 11 - PHOTOCELLS

The unit has two inputs for photocells (normally closed contact), which can be independently enabled and associated with different functions:

### 1. Photocell active during opening and closing phases

- During the movement of the gate, in any direction, if the photocell is interrupted the gate stops; when the interruption is removed the gate opens completely.
- With the gate closed, if the photocell is interrupted the start-up commands are rejected.
- With the gate open, if the photocell is interrupted the pause time is reset, and the closing commands are rejected.

Connect the N.C. output of the photocell between terminals **S5** and **S9** (configure the **FOT1** parameter on **APCH**)

### 2. Photocell activated when closing and gate stopped

- During opening if the photocell is interrupted has no effect
- During closing, if the photocell is interrupted the gate completely re-opens
- With the gate closed, if the photocell is interrupted the start-up commands are rejected.
- With the gate open, if the photocell is interrupted, the pause time is reset and the closing commands are rejected.

Connect the N.C. output of the photocell between terminals **S6** and **S9** (configure the parameter **FOT2** on **CFCH**)

### 3. Photocell activated only during closing

- During opening and with the gate closed, if the photocell is interrupted has no effect
- During closing, if the photocell is interrupted the gate completely re-opens
- With the gate open, if the photocell is interrupted, the pause time is reset and the closing commands are rejected.

Connect the N.C. output of the photocell between terminals **S6** and **S9** (configure the parameter **FOT2** on **CFCH**)



#### WARNING:

- If you connect multiple photocells on the same terminal, the connection must be done in series: all photocells will have the same function.
- If you do not connect any photocell to terminal **S5**, the menu **FOT1** must be set to **NO**.
- If you do not connect any photocell to terminal **S6**, the menu **FOT2** must be set to **NO**.

Regardless of the selected function, if the photocells are activated during the pause, the pause time is reset using the value set in parameter **CH.AU**.

If you want to accelerate the closing of the gate, after the transit, set a value for the parameter **CH.TR** lower than **CH.AU**'s. The pause time can be reset using the value of **CH.TR**.

If you want to stop the gate after transit through the photocells, set the value **YES** for the parameter **PA.TR**

**NOTE:** if the photocells are connected on the two **FOT1** and **FOT2** inputs the gate stops only after the passage in front of both photocells have been detected

## 11.1 - POWER OF PHOTOCELLS AND AND FUNCTIONAL TEST

Photocells can be powered to 24 Vac (FIG.1) or 12 Vdc (FIG.2). Regardless of the selected function, the photocells can be tested prior to each movement.

To enable the photocell test it is required to indicate the maximum duration of the test in the parameter **FO.TE**: if set to **NO**, the test is not carried out.

### **POWER SUPPLY 24VAC**

Connect the power supply of photocell receivers between terminals **E1** and **E3 (COM)**.

Connect the power supply of photocell transmitters between terminals **E5** and **E3 (COM)**.

**NOTE:** to facilitate wiring the terminals for the AC power supply are double (E1 = E2 / E3 = E4)

**WARNING:** To carry out the test it is necessary that the transmitter power of the photocells is connected to the terminals **E5** and **E3 (COM)**

### **POWER SUPPLY 12VDC**

The DC power supply is available between terminals **H8 (+)** and **H7 (-)**.

**ATTENTION:** In order to perform the test, one of the relay options must be used:

- **REL1:** connect the transmitter power supply between terminals **Z3 (+)** and **H7 (-)** and connect the terminal **H8** with the terminal **Z4**, set the **REL1** parameter to **TEST**.
- **REL2:** connect the transmitter power supply between terminals **Z5 (+)** and **H7 (-)** and connect the terminal **H8** with the terminal **Z6**, set the **REL2** parameter to **TEST**.



**FIG. 1** 24Vac

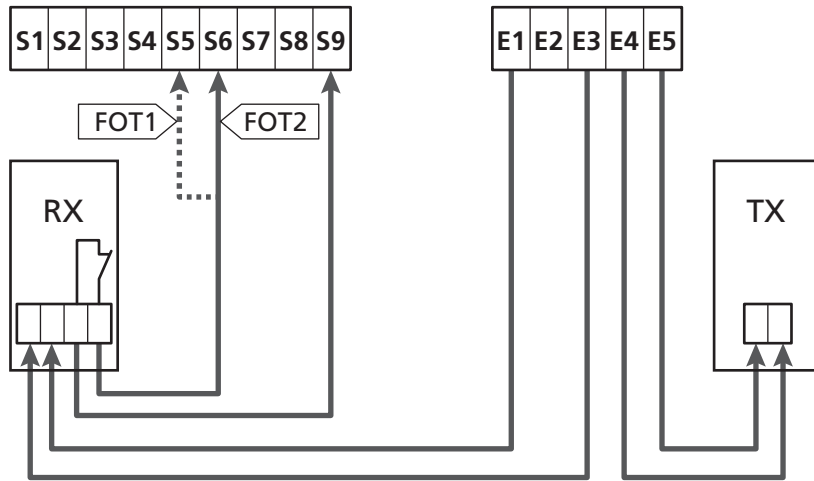

FOT1 parameter ⇨ DEFAULT = NO (no function)

FOT2 parameter ⇨ DEFAULT = CFCH (enabled when closing and with closed gate)

**FIG. 2** 12Vdc

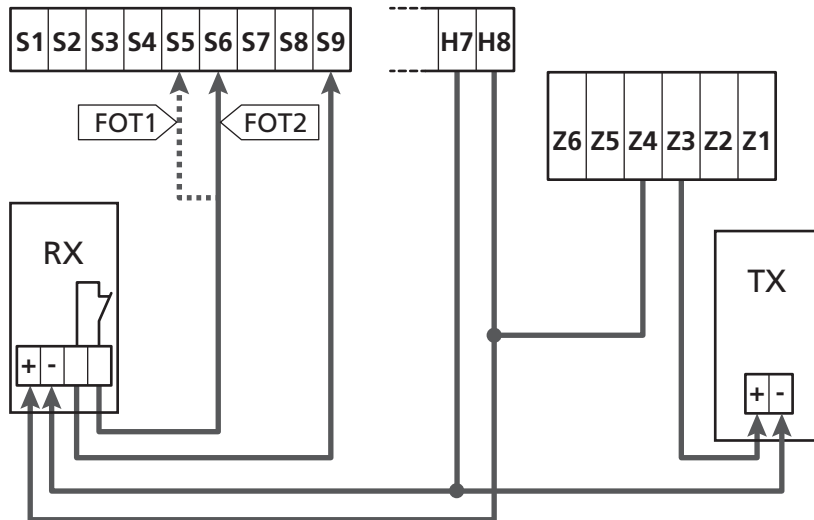

## 12 - DETECTION OF OBSTACLES (AMPEROMETRIC SENSOR / SAFETY RIBBONS)

The presence of an obstacle that prevents the movement of the gate can be detected in several ways:

1. Amperometric sensor
2. Safety ribbons

**!** Following detection of an obstacle during closure, the gate reopens and the behaviour of the power centre depends on various parameters, with the following priority:

1. If the clock mode is active ( `MODE = DRCL` ), counting of the pause time for automatic closure is activated.
2. If the gate is closed without withdrawing, or if closure after the obstacle is manual ( `CH.OS = MAN` ), counting of the pause time for automatic closure is NOT activated and the gate will start moving again after the next start-up command is given
3. If closure after the obstacle is automatic ( `CH.OS = AUTO` ), the centre will behave according to the settings of the `CH.AU` parameter

### 12.1 - AMPEROMETRIC SENSOR

An unexpected increase in the consumption of current by the motor is meant as the result of the presence of an obstacle. This feature is automatic and requires no settings.

### 12.2 - SAFETY RIBBONS

The unit detects the presence of an obstacle when a safety ribbon is pressed.

The unit has two inputs for the ribbons, which can be independently enabled and associated with different types of function.

Connect the active ribbons during opening between the terminals **S7** and **S9**.

Enable the operation of the ribbons through the parameter `COS1`:

- If you set `AP` the operation of the ribbon is detected only during opening and the gate reverses the movement for 2.5 seconds
- If you set `APCH` the operation of ribbon is detected during the opening and closing: when opening the gate reverses the movement for 2.5 seconds, while when closing the gate is stopped

Connect the active ribbons when closing between terminals **S8** and **S9**.

Enable the operation of the ribbons through the parameter `COS2`:

- If you set `CH` the operation of the ribbon is detected only during closing and the gate reverses the movement for 2.5 seconds
- If you set `APCH` the operation of the ribbon is detected during closing and opening: when closing the gate reverses the movement for 2.5 seconds, while when opening the gate is stopped

### **!** WARNING:

- If you do not connect any ribbon to the terminal **S7**, the parameter `COS1` must be set to `NO`.
- If you do not connect any ribbon to the terminal **S8**, the parameter `COS2` must be set to `NO`.

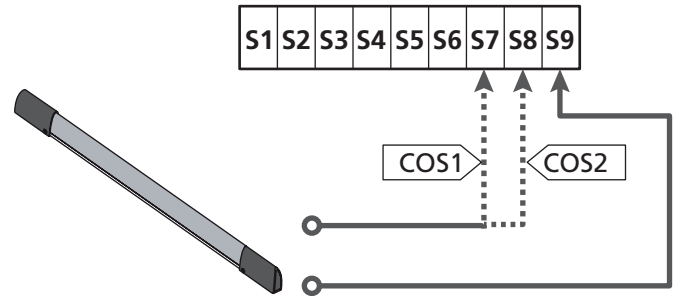

`COS1` parameter ⇨ DEFAULT = `NO` (no function)

`COS2` parameter ⇨ DEFAULT = `NO` (no function)

The unit can operate with different types of ribbons; depending on the type of ribbon used it is required to correctly set the parameter `CO.TE`

**NOTE:** You can not use different types of ribbons on two `COS1` and `COS2` inputs.

#### a. Mechanical ribbons with normally closed contact

Set the parameter `CO.TE` with the value `NO`: not test is run before the movements.

#### b. Optical ribbons

Set the parameter `CO.TE` with the value `FOTO`: before any movement a functional test similar to that of photocells is carried out. If you do not want the test to be run, set `NO`.

Connect the power supply of the optical ribbons following the instructions described in chapter 11.1

#### c. Ribbon with resistive rubber

Set the parameter `CO.TE` with the value `RESI`: the unit is expected to measure an impedance equal to 8.2 kohms, and an alarm is triggered if a lower impedance (pressed ribbon) or a higher impedance (interrupted wire) are detected, therefore it is not necessary to run the test before the movements.

**!** **WARNING:** If you connect multiple ribbons to the same terminal, the connection must be made in series, except in the case of resistive ribbons which which must be connected in parallel.

### 13 - BLINKER

The HEAVY1 unit has two outputs for the management of the blinker:

- Z1** and **Z2** terminal for a 230V - 40W blinker with internal intermittence
- H6 (+)** and **H7 (-)** terminals for a 24Vdc - 3W blinker.  
Using a 24V blinker you need to set the **SPIA** parameter with the value **FLASH** (DEFAULT = **W.L.**).

**NOTE:** If these terminals are used for this function it will not be possible to connect a open gate warning light.

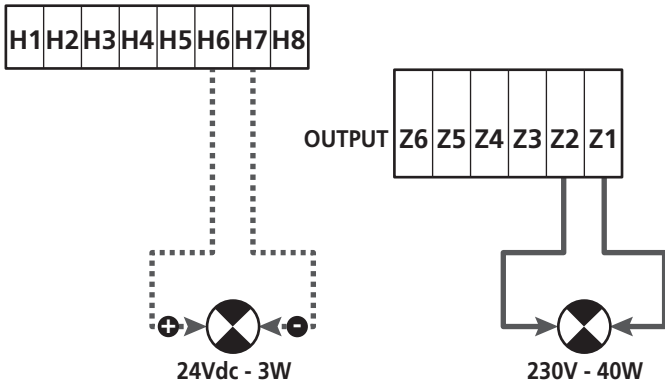

The normal operation of the blinker involves its activation during both opening and closing of the gate.

The other options available are:

- Enabled blinker set to pause: you need to set the value **SI** for the parameter **LP.PA**
- Pre-flashing: the blinker is activated before the beginning of the opening and closing phases for a time that can be set via the parameter **T.PRE**
- Pre-flashing during closing: the blinker is activated before the closing phase for a time other than that set for opening. The time can be set via the parameter **T.PCH**

### 14 - OPEN GATE WARNING LIGHT

The unit is fitted with a 24Vdc - 3W output that allows the connection of a warning light.

The open gate warning light shows in real time the status of the gate, the type of flashing indicates the four possible conditions.

- GATE STOPPED (CLOSED): the light is off
- GATE IN PAUSE MODE (OPEN): the light is on and fixed
- OPENING GATE: the light flashes slowly (2Hz)
- CLOSING GATE: the light flashes fast (4Hz)

Connect the cables of the warning light to terminals **H6 (+)** and **H7 (-)**

**NOTE:** if these terminals are used for this function it will not be possible to connect a 24Vdc blinker

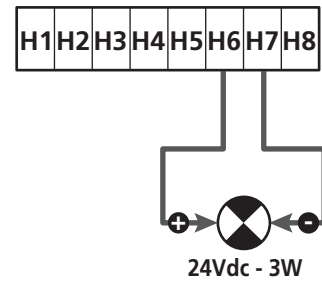

**SPIA** parameter ⇨ DEFAULT = **W.L.** (open gate warning light)

### 15 - EXTERNAL ANTENNA

To guarantee the maximal radio range radio it is advisable to use the external antenna.

Connect the shield of the antenna to the terminal **A1** and the hot pole to the terminal **A2**.

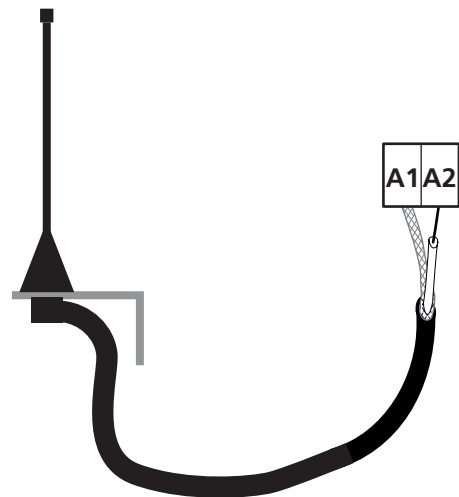

## 16 - CONTROL MODE FROM TERMINAL BOARD

To control the gate through external devices you need have to connect devices with normally open contact between terminals **S1-S4**, **S2-S4** or **S3-S4** and set for each the desired function via the parameters **ING1**, **ING2** and **ING3**.

The functions available are:

- **Start** (**START** value to be set)  
This function corresponds to a generic activation command and controls the following operations:
  - When the gate is closed, an opening cycle starts
  - When the gate is opening depends on the setting of parameter **ST.AP**:  
**NO**: command not active  
**CHIU**: the gate closes immediately  
**PAUS**: the gate stops (if the automatic closing mode is on the pause time counting starts)
  - When the gate is open and the pause the counting is not active, the closing starts
  - When the gate is open and the pause time counting is active, depends on the menu **ST.PA**:  
**NO**: command not active  
**CHIU**: closing starts  
**PAUS**: reset the pause time counting
  - When the gate is closing depends on the menu **ST.CH**:  
**APRE**: the gate re-opens  
**STOP**: the gate will stop and the cycle is considered finished
  - When the gate is stopped due to a stop command or the detection of an obstacle, a command Start restarts the gate in the same direction as it was before being stopped.  
If the parameter **STOP** is set to **INVE** the gate again moves, but in the opposite direction.
  - When the gate began a partial opening cycle commands a total opening
- **Partial start** (**ST.PE** value to be set)  
This function corresponds to a partial opening command and controls the following operations:
  - When the gate is closed, a partial opening cycle starts; the gate opens only for the percentage of travel set in the parameter **P.APP**
  - When the gate began a normal opening cycle this command has no effect.
  - Once the gate has started a partial opening cycle, it is dependent on the menu **SP.PA**:  
**PAUS**: the gate stops and pauses  
**CHIU**: the gate immediately starts closing  
**NO**: the gate continues to open (the command is ignored)

- **Stop** (**STOP** value to be set)  
This function corresponds to a stop command: it is the only case in which the connected device must work with normally closed contact; it can be used to stop the gate and hold it in a locked position.

The operation of the STOP command depends on the value set for the parameter **STOP**:

- **PROS**: the gate stops in its current position and as long as the contact is open no command is effective.  
Once the contact is closed again, any start command restarts the gate that follows its previous direction.
- **INVE**: the gate stops in its current position and as long as the contact is open no command is effective.  
Once the contact is closed again, any start command restarts the gate in the opposite direction.
- **APRE**: the gate stops any movement and opens completely. If an active safety device prevents the opening, the gate does not move until the device involved is deactivated, then it opens.  
So the gate remains locked in the open position until the STOP contact closes again.
- **CHIU**: the gate does not stop the movement immediately, but when it stops it closes.  
If a safety device causes its re-opening, the operation is carried out, then again closing is commanded.  
When the gate is closed, it remains locked in this position until the STOP contact is closed again.

- **Always opens** (**APRE** value to be set)  
Always controls the opening, regardless of the position of the gate, if the gate is already open, it is ineffective.

**NOTE**: This command is not available for the input **ING3**.

- **Always closes** (**CHIU** value to be set)  
Always control the closing: if the gate is already closed it is ineffective.

**NOTE**: This command is not available for the input **ING3**.

- **Force dead man mode** (**PRES** value to be set)  
This command is available only on the input **ING3**: when the contact is closed the unit is operating in dead man mode.

## 17 - REMOTE CONTROL MODE

The HEAVY1 unit is fitted for the connection of an MR series receiver. The receiver has 4 channels, which can be associated with the buttons on the remote control and can have the following functions:

- Channels 1 and 2 trigger the opening cycle according to the setting of the parameter **FX**:  
**START**: channel 1 is equivalent to START command and channel 2 to PARTIAL START command  
**APCH**: channel 1 is equivalent to the command OPEN and channel 2 to the command CLOSE
- Channel 3 is equivalent to the STOP command

- Channel 4 operates according to the setting of the parameter **AUX**:  
**MON**: monostable. The contact of an option relay (REL1-2-3) set as courtesy light is kept closed as long as the channel is active.  
**BIST**: bistable. The contact of an option relay (REL1-2-3) set as courtesy light is switched every time the channel is activated.  
**TIM**: timer. The contact of an option relay (REL1-2-3) set as courtesy light is kept closed for the time set. If the channel is again activated, the time count is reset.  
**TOUT**: time out. The contact of an option relay (REL1-2-3) set as courtesy light is kept closed for the set time. If the channel is again activated, the relay contact is opened.  
**PRES**: force dead man mode. At each activation of the channel the unit switches between the operating mode set and the dead man mode.

## 18 - OPERATING MODES

The operating mode of controls depends on the settings of the parameter **MODE**.

- **Pulse mode (MODE = STAN)**  
 A command opens the gate. The manoeuvre ends when the limit switch is activated, when another command is received or when a safety device is activated. When the automatic closing is enabled the gate closes after the pause time set (parameter **CHAU**)
- **Clock mode (MODE = CLOCK)**  
 This function allows to delay the opening of the gate through an external clock. The operation is identical to the mode **STAN**, but the pause time count is suspended until the contact of the device connected to an input configured as **STRT**, **STPE** or **APRE** is closed.  
 To use this feature, you must enable the automatic closing (parameter **CHAU**)
- **Dead man mode (MODE = PRES)**  
 The command must be kept active for the entire duration of the movement of the gate; when the command is suspended the gate stops immediately. In this mode, the **START** command launches alternately the opening and closing.
- **Mixed mode (MODE = S.PRE)**  
 The opening movements are controlled by pulses and the closing ones in dead man mode.  
 A gate that moves in dead man mode stops if a safety device is activated; it is not possible to reverse the movement of the gate as during normal operation.

## 19 - SPECIAL OPERATING MODES

The **HEAVY1** unit has some special operating modes, to be used only in special cases.

### DEAD MAN MODE

The dead man mode can be temporarily forced through a command on terminal **S3**: when the contact is closed, the mode is activated (the parameter **ING3** must be set to **PRES**).

### EMERGENCY DEAD MAN MODE

This operational mode can be used to move the gate in **DEAD MAN** mode in particular cases, such as installation/maintenance or in the case of malfunctioning of photocell, edge, limit switches or encoder.

To activate the function the **START** command must be pressed 3 times (presses must last at least 1 second; the pause between commands must last at least 1 second).

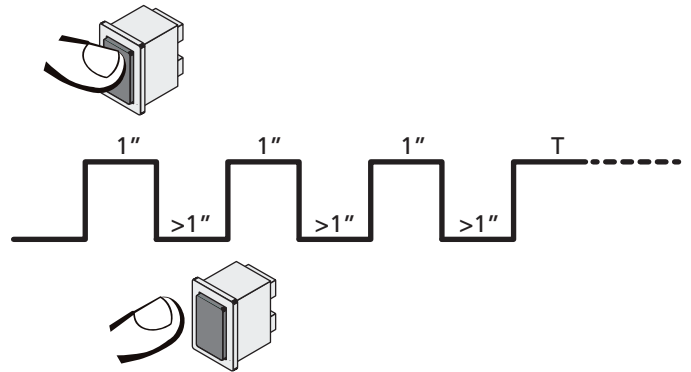

The fourth **START** command activates the gate in **MAN PRESENT** mode. To move the gate keep the **START** command pressed for the duration of the operation (time **T**). The function will automatically turn off after 10 seconds of inactivity of the gate.

**⚠ WARNING: during the emergency movement the safety device considered defective is not taken into account: all its activation will be ignored**

### MANUAL HANDLING

During installation or maintenance, you can move the gate through the buttons **↑** and **↓** placed next to the display.

The operation mode is always dead man:

**↑** opens and **↓** closes the gate.

The speed of the gate is determined by the value set for the parameter **VEL.M**

**⚠ WARNING: all the safety devices are ignored (except for the Emergency STOP), then it is the operator's responsibility to make sure that there are no obstacles on the travel path of the gate.**

During manual handling, the display shows some information on the operation of the inverter: voltage, current on the motor and temperature of the driver.

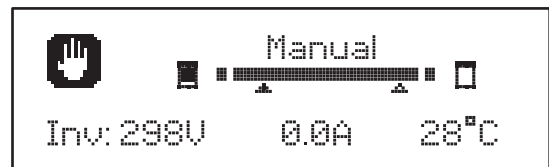

**NOTE:** It is possible to read this information without moving the gate with a quick pressure on one of two **↑** and **↓** buttons.

The manual handling mode remains active for 1 minute, then the unit returns to normal operation.

To immediately return to normal operation, press the **OK** button for 1 second.

## 20 - OPTION RELAY OUTPUT

The unit has three relay outputs with normally open dry contact that can be configured with different functions through the parameters REL1, REL2 and REL3

In this table are the available functions and the value to set for the parameters REL1, REL2 and REL3

FUNCTION	REL1	REL2	REL3	VALUE
Lock	•			SERR
Opening command	•			APRE
Closing command		•		CHIU
Service reporting		•		SERV
Safety devices test	•	•		TEST
Custom	•	•		CUST
Courtesy light	•	•	•	LUCI
Indication of movement			•	MONO MONC

Connect the device controlled by the REL1 output to terminals **Z4** and **Z3**

Connect the device controlled by the REL2 output to terminals **Z6** and **Z5**

Connect the device controlled by the REL3 output to terminals **B2** and **B1**

**⚠ The relay outputs act as simple switches and do not provide any power supply.**

The power supply to the device  $V_{SUPPLY}$  can be provided by the unit or the line.

If you use the power supply of accessories, 24 Vac or 12 Vdc, make sure that the current required is compatible with that supplied by the unit.

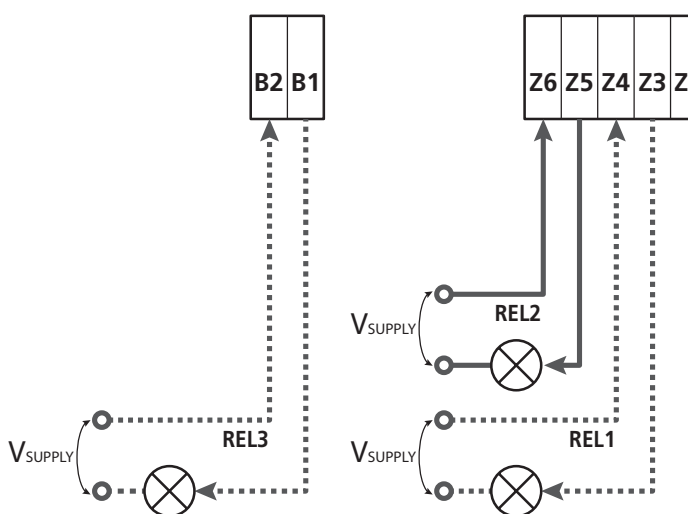

REL1 parameter ⇔ DEFAULT = LUCI (courtesy light)

REL2 parameter ⇔ DEFAULT = NO (no function)

REL3 parameter ⇔ DEFAULT = NO (no function)

## 20.1 - COURTESY LIGHT

The courtesy lights can be operated in the following ways:

### 1. Timer control

The lights turn on when the opening is commanded and stay on for the time set.

Select the value T.LUC in the parameter LUCI and set the desired time.

### 2. Moving + timer

The lights turn on when the opening is commanded; when the gate stops (open or closed) the lights stay on for the time set.

Select the value CICL in the parameter LUCI and set the desired time.

### 3. Timer by AUX control

The lights are activated by a remote control stored on channel 4 of the MR receiver and stay on for the time set.

Select the value TIM in the parameter AUX and set the desired time.

### 4. Light monostable

The lights are activated by a remote control stored on channel 4 on the receiver MR and stay on for the whole duration of the command transmission.

Select the value MONO in the parameter AUX

### 5. Light bistable

The lights are activated by a remote control stored on channel 4 of the receiver MR: a first command turns on the lights, a second command turns them off.

Select the value BIST in the parameter AUX

### 6. Bistable + timeout

The lights are activated by a remote control stored on channel 4 of the MR receiver and stay on for the time set.

A second transmission before time runs out turns off the lights. Select the value TOUT in the parameter AUX and set the desired time.

## 20.2 - LOCK

The relay is closed for three seconds each time a new opening manoeuvre is started.

To facilitate the release of the lock you can set a time for the water hammer: before you start opening the gate is controlled to close for a short time.

To activate this function, set the backlash time through the T.AF

## 20.3 - SERVICE REPORTING

The relay is activated when the cycle count set for the Service request reaches  $\infty$  (Chapter 22.4): in this way it is possible to activate a warning light.

## 20.4 - OPENING COMMAND

The relay is activated when the motor is controlled when opening: in this way it is possible to activate secondary motors or send synchronized signals with the movement of the main motor.

## 20.5 – CLOSING COMMAND

The relay is activated when the motor is controlled when closing: in this way it is possible to activate secondary motors or send synchronized signals with the movement of the main motor.

## 20.6 - SAFETY DEVICE TESTS

The relay is activated simultaneously with the relay dedicated to the test of photocells: in this way it is possible to perform the function test on devices that DO NOT use the 24 Vac power supply on terminal **E5**, for example devices powered to 12 Vdc.

## 20.7 - CUSTOM

This feature is intended primarily for connecting warning light devices.

Programming this parameter allows you to define the state of the relay options selected in these 5 situations:

WAITI: closed gate, unit waiting for command  
 OPENI: opening gate  
 CLOSI: closing gate  
 PAUSE: gate open and running count of the automatic closing time  
 STOP: gate open without counting the automatic closing time

To program proceed as follows:

1. Select the value **CUST** and press **OK**: the display shows

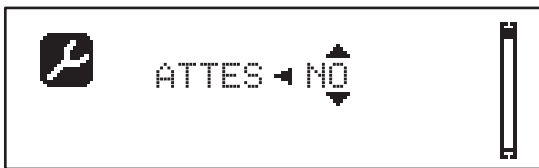

2. Using the buttons **↑** and **↓** select the status of the relay in this situation:  
 NO: relay contact open  
 SI: relay contact closed
3. Press the **OK** button to scroll through the available 5 situations and select the status of the relay through the buttons **↑** and **↓**

## 20.8 - INDICATION OF MOVEMENT

The relay is activated when the motor is operated. The relay can operate with normally open or normally closed contact, select the desired option by setting the parameter **REL3**:

- Select the value **MO.NO** for normally open contact
- Select the value **MO.NC** for normally closed contact

## 21 - ADI INTERFACE

The ADI (Additional Devices Interface) interface of the control unit allows the connection to V2 optional modules.

Refer to V2 catalogue or to the technical sheets to see which optional modules with ADI interface are available for this control unit.



**WARNING: Please read the instructions of each single module to install the optional modules.**

For some devices, it is possible to configure the mode for interfacing with the control unit; in addition, it is necessary to enable the interface so that the control unit can process the signals arriving from the ADI device.

Please refer to the I.ADI programming menu to enable the ADI interface and access the device configuration menu.

When the device is enabled, the display shows the word **Adi** at the top right:



ADI devices use the display of the control unit to issue alarms or display the configuration of the control unit:

- **PHOTOCELL ALARM** - the segment at the top turns on: the gate stops, when the alarm ceases the gate restart in opening.
- **RIBBON ALARM** - The bottom segment turns on: the gate reverses for 3 seconds.
- **STOP ALARM** - The lowest segment turns on: the gate stops and cannot restart until the alarm is disabled.
- **SLAVE** - When you use a SYNCHRO module instead of the word **Adi**, **SLV** turns on to indicate when the unit is configured as SLAVE



## 22 - PROGRAMMING

The programming of the functions and times of the unit is carried out through the configuration menus, accessible and searchable through the 3 buttons ↑, ↓ and **OK** placed next to the display of the unit.

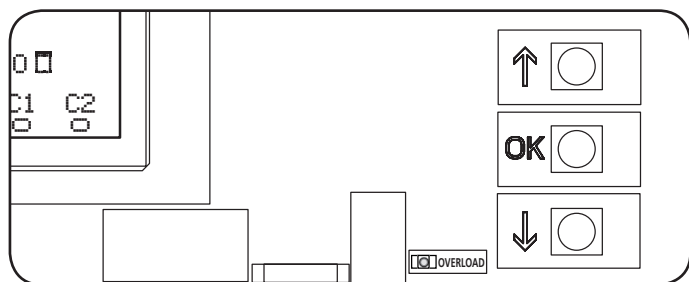

- By pressing **OK** button you can access the programming and configuration menus of each individual parameters
- By pressing the button ↓ you will switch to the next item
- By pressing the button ↑ you return to the previous item

**WARNING:** Outside of the configuration menu, the buttons ↑ and ↓ activate the motor in DEAD MAN mode. The button ↑ activates the command OPEN and the button ↓ activates the command CLOSE.

**WARNING:** These commands activate the motor without taking into account the status of safety devices.

### 22.1 - ACCESS TO MAIN PROGRAMMING MENUS

1. Press and hold the **OK** button until the display shows the desired menu

PRG	Programming of the operating parameters (Chapter 22.5)
CNT	Cycle Counter (Chapter 22.4)
SET	Learning of the travel (Chapter 22.3)
DEF	Loading DEFAULT parameters (Chapter 22.2)

2. Release the **OK** button: the display shows the first item in the sub-men or the options available for the function.

PRG	MODE
CNT	Total / Service
SET	Learn / Exit
DEF	Load default / Exit

3. Using the buttons ↑ ↓ and **OK** select and edit the parameters needed

**CAUTION:** if you do not carry out any operation for more than 1 minute, the unit exits from the programming mode, without storing the settings and changes made are lost.

### 22.2 - LOADING DEFAULT PARAMETERS

If necessary, you can reset all parameters to their DEFAULT values (see table on page 52)

**WARNING:** This procedure involves the loss of all customized parameters.

1. Press and hold the **OK** button until the display shows DEF
2. Release the **OK** button: the display shows

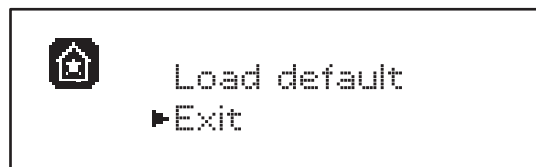

3. To exit the function, select **Exit** using the ↑ ↓ and press **OK** to confirm
4. To load the DEFAULT data select **Load default** using the ↑ ↓ buttons and press **OK**. Then select **Yes** and press **OK**: all parameters are re-written with their DEFAULT value, the unit leaves the programming mode and the display shows the control panel

### 22.3 - TRAVEL LEARNING

This function allows you to store the limit switches. The recorded values are useful for all the programming parameters that are based on a percentage of the travel.

1. Press and hold the **OK** button until the display shows SET
2. Release the **OK** button: the display shows

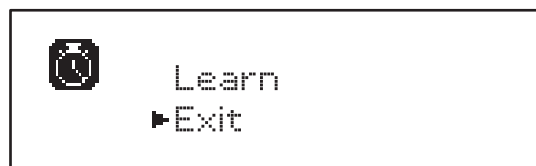

3. To exit the function, select **Exit** using the ↑ ↓ and press **OK** to confirm
4. To start the learning procedure of the travel select **Learn** through the buttons ↑ and ↓ and press then **OK**
5. Press the ↑ key to start the opening travel learning: the gate opens until it reaches the limit switch
6. Press the ↓ key to start the closing travel learning: the gate closes until it reaches the limit switch

**WARNING:** the intervention of any safety devices stops the self-learning cycle. To restart it is necessary to resume the procedure from the beginning.

7. Press the **OK** button to store the travel and exit the function



## 22.4 - READING THE CYCLE COUNTER

The HEAVY1 unit takes into account the completed opening cycles of the gate and, if requested, reports the need for maintenance after a fixed number of manoeuvres.

There are two counters available:

- Non resettable counter of the opening cycles completed (**total**)
- Counter showing the cycles to be performed before the next maintenance (**service**)  
This second counter can be programmed with the desired number of cycles.

1. Press and hold the **OK** button until the display shows **CNT**
2. Release the **OK** button: the display shows

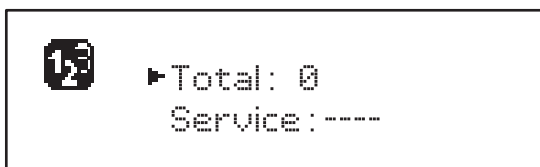

3. To activate the maintenance request select the **Service** function and press **OK**
4. Set the desired number of cycles (the step consists of 250 cycles)
5. Press **OK** to confirm the display shows the control panel

When the Service counter reaches 0 the unit sends the request for maintenance, that can also be signalled in two ways:

1. **Warning light:** the option relay REL2 closes to activate a warning light (Chapter 23)
2. **Pre-flashing:** if you do not connect a dedicated warning light the unit indicates the request for service through an additional pre-flashing of 5 seconds at the beginning of each opening cycle

To disable the signalling it is necessary to access the **Service** counter menu and again program the number of cycles after which the maintenance will be required.

If set to 0, the signalling function for the request for service is disabled and the signal is not repeated.

 **WARNING: maintenance operations should only be carried out by qualified staff.**

## 22.5 - PROGRAMMING THE OPERATING PARAMETERS

1. Press and hold the **OK** button until the display shows **PRG**
2. Release the **OK** button: the display shows:
  - the first parameter of the programming menu: **MODE**
  - the currently set value (**STAN**)
  - a scroll bar useful for detecting the position of the parameter within the programming menu
  - a message describing the parameter



3. To change the value of this parameter press the **OK** button: the arrows move to the the value



4. Select the desired value using the buttons **↑** and **↓**
5. Press the **OK** button to confirm and exit the parameter. The display shows again:



6. Using the buttons **↑** **↓** and **OK** select and edit the necessary parameters: the following pages show a table with all programming values, the selectable values. the values set by **DEFAULT** and a short description of the function.

**NOTE:** If you hold the buttons **↑** or **↓** the items of the configuration menu scroll in a fast way, until the item **FINE** is displayed

 The last menu item **FINE** stores the changes made, exit the programming menu and return to normal operation of the system.

To avoid losing your configuration is mandatory to exit from the programming mode through this menu item.

 **CAUTION: if you do not carry out any operation for more than 1 minute, the unit exits from the programming mode, without storing the settings and changes made are lost.**

## 22.6 - TABLE OF PROGRAMMING PARAMETERS

PARAMETER	VALUE	SUBMENU	DESCRIPTION	DEFAULT	CHAPTER	MEMO
MODE			<b>Working mode</b>	STAN	18	
	STAN		Standard			
	PRES		Dead man			
	S.PRE		Mixed			
	OROL		Timer			
DIR			<b>Gate direction (the direction you see from the inside)</b>	DX		
	DX		The gate opens rightwards			
	SX		The gate opens leftwards			
P.APP	0-100%		<b>Partial opening</b>	50%		
T.PRE	0.5"-10.0"		<b>Pre-blinking time before opening</b>	10"	13	
	NO		Function disabled			
T.PCH	0.5"-10.0"		<b>Pre-blinking time before closing</b>	NO	13	
	NO		Pre-flashing during closing equal to T.PRE			
POT	30-100%		<b>Motor power</b>	100	9	
VEL	5-99HZ		<b>Normal speed</b>	50	9	
VEL.R	5-99HZ		<b>Slowed speed</b>	25	9	
SPUN	0-30%		<b>Over voltage at start opening</b>	0	9	
ACCEL	0-6		<b>Starting ramp</b>	2	9	
DECEL	0-6		<b>Slowing ramp</b>	2	9	
FRENO	0-10		<b>Brake intensity</b>	4	9	
RAL.A	0-50%		<b>Slowed opening run</b>	10%	9	
RAL.C	0-50%		<b>Slowed closing run</b>	10%	9	
VEL.M	5-99HZ		<b>Speed in manual operation</b>	30	19	
ST.AP			<b>Start during the opening phase</b>	PAUS	16	
	PAUS		The gate stops and pauses			
	CHIU		The gate immediately starts closing			
	NO		The gate continues to open (the command is ignored)			
ST.CH			<b>Start during the closing phase</b>	STOP	16	
	STOP		The gate stops and the cycle is considered as complete			
	APRE		The gate re-opens			
ST.PA			<b>Start during pause</b>	CHIU	16	
	CHIU		The gate starts closing			
	NO		This command is ignored			
	PAUS		The pause time is reset			

PARAMETER	VALUE	SUBMENU	DESCRIPTION	DEFAULT	CHAPTER	MEMO
SP.AP			<b>Pedestrian Start during the partial opening phase</b>	PAUS	16	
	PAUS		The gate stops and goes to pause			
	CHIU		The gate immediately starts closing			
	NO		The gate goes on with the opening phase (command is ignored)			
CH.AU	0.5"-20'		<b>Pause time for automatic closing</b>	NO	18	
	NO		Function disabled			
CH.TR	0.5"-20'		<b>Pause time after transit</b>	NO	11	
	NO		Function disabled			
PA.TR			<b>Pause after transit</b>	NO	11	
	NO		Function disabled			
	SI		Function enabled			
LUCI			<b>Courtesy light</b>	T.LUC	20	
	T.LUC	0.0"-20'	Timer after command	1.0'		
	NO		Function disabled			
	CICL	0.0"-20'	Moving + timer			
AUX			<b>AUX radio channel function</b>	TIM	20	
	TIM	0.0"-20'	Timer light	1.0'		
	BIST		Bistable light			
	MONO		Monostable light			
	PRES		Forced dead man mode		17	
	TOUT	0.0"-20'	Bistable + time out			
SPIA			<b>24V output setup</b>	W.L.	14	
	W.L.		Warning light			
	FLASH		Blinker			
	NO		No function			
LP.PA			<b>Blinker during pause time</b>	NO	13	
	NO		During the pause the blinker is off			
	SI		During the pause, the blinker is on			

PARAMETER	VALUE	SUBMENU	DESCRIPTION	DEFAULT	CHAPTER	MEMO
REL1			<b>Relay 1 set up</b>	LUCI	20	
	LUCI		Courtesy lights			
	NO		No function			
	CUST		Custom		20.7	
		WAITI	Relay contact closed while waiting for commands			
		OPENI	Relay contact closed during tests and the opening			
		CLOSI	Relay contact closed when closing			
		PAUSE	Relay contact closed during the pause			
		STOP	Relay contact closed when the gate is open and automatic closing is disabled (parameter CHAU)			
	TEST		12Vdc test			
	APRE		Open command			
	SERR		Lock			
REL2			<b>Relay 2 set up</b>	NO	20	
	NO		No function			
	CUST		Custom		20.7	
		WAITI	Relay contact closed while waiting for commands			
		OPENI	Relay contact closed during tests and the opening			
		CLOSI	Relay contact closed when closing			
		PAUSE	Relay contact closed during the pause			
		STOP	Relay contact closed when the gate is open and automatic closing is disabled (parameter CHAU)			
	TEST		12Vdc test			
	CHIU		Close command			
	SERV		Service indicator			
	LUCI		Courtesy lights			
REL3			<b>Relay 3 set up</b>	NO	20	
	LUCI		Courtesy lights			
	NO		No function			
	MO.NO		Indication of movement (N.O. contact)			
	MO.NC		Indication of movement (N.C. contact)			

PARAMETER	VALUE	SUBMENU	DESCRIPTION	DEFAULT	CHAPTER	MEMO
ING1			<b>Input 1 set up</b>	START	16	
	START		Start cycle (N.O. contact)			
	NO		No function			
	CHIU		Always close (N.O. contact)			
	APRE		Always open (N.O. contact)			
	STOP		Stop (N.C. contact)			
	ST.PE		Partial open (N.O. contact)			
ING2			<b>Input 2 set up</b>	ST.PE	16	
	ST.PE		Partial open (N.O. contact)			
	START		Start cycle (N.O. contact)			
	NO		No function			
	CHIU		Always close (N.O. contact)			
	APRE		Always open (N.O. contact)			
	STOP		Stop (N.C. contact)			
ING3			<b>Input 3 set up</b>	NO	16	
	NO		No function			
	PRES		Force dead man mode (N.O. contact)			
	STOP		Stop (N.C. contact)			
	ST.PE		Partial open (N.O. contact)			
	START		Start cycle (N.O. contact)			
RX			<b>Receiver mode</b>	START	17	
	START		Channel 1 = START Channel 2 = PARTIAL START			
	APCH		Channel 1 = OPEN Channel 2 = CLOSE			
STOP			<b>Stop command function</b>	PROS	16	
	PROS		Stop then resume			
	CHIU		Close then hold			
	APRE		Open then hold			
	INVE		Stop then invert			
FOT1			<b>Photocell 1 mode</b>	NO	11	
	NO		No function			
	APCH		Enabled in opening and closing			
FOT2			<b>Photocell 2 mode</b>	CFCH	11	
	CFCH		Enabled with gate closed and during closing phase			
	CH		Enabled closing phase			
	NO		No function			

PARAMETER	VALUE	SUBMENU	DESCRIPTION	DEFAULT	CHAPTER	MEMO
FT.TE	0.1"-2.0"		<b>Photocell test enable</b>	NO	11.1	
	NO		Function disabled			
COS1			<b>Safety ribbon 1 mode</b>	NO	12.2	
	NO		No function			
	APCH		Enabled opening and closing			
	AP		Enabled opening			
COS2			<b>Safety ribbon 2 mode</b>	NO	12.2	
	NO		No function			
	APCH		Enabled closing and opening			
	CH		Enabled closing			
CO.TE			<b>Ribbon type and test</b>	NO	12.2	
	NO		Mechanic - no test			
	RESI		Resistive			
	FOTO		Optical with test			
CH.OS			<b>Closure after obstacle</b>	MAN	12	
	MAN		Manual			
	AUTO		Automatic (if activated through CH.AU parameter)			
I.ADI			<b>ADI device enable</b>	NO	21	
	NO		ADI interface disabled			
	SI		ADI interface enabled			
RICH			<b>Reclosing at startup</b>	SI		
	NO		Function disabled			
	SI		When the power supply is activated the unit set for closing: the first START command starts the motor closing. If the automatic closing is activated (CH.AU), the count of pause time starts and closing is activated			
T.ADD	0.5"-1'		<b>Extra travel</b> If in some cases the gate does not reach the position needed to activate the limit switch, you can set an additional time by configuring the parameter T.ADD: if the limit switches is not activated the gate continues its movement up to the end of the set time	1.0"		
	NO		The gate ends its travel even if the limit switches have not been activated			
FINE			<b>Exit the programming menu</b>	NO		
	NO		Do not exit the programming menu			
	SI		Exits the programming menu by storing the parameters set			

## 23 - OPERATION DEFECTS

This paragraph shows some possible operation defects, along with their cause and applicable remedy.

DISPLAYING	DESCRIPTION	SOLUTION
POWER LOGIC led off	Faulty power supply of logics	Check fuse F1
POWER MOTOR led off	Faulty power supply of the inverter	Check fuse F2
ERROR led on	Faulty inverter	Send the unit to the service department
ATTENTION led flashing	Charging inverter	The gate does not move: When the LED turns off the inverter is ready and the operation can start
ATTENTION led on	Emergency stop enabled	Turn off the STOP button between terminals T1 and T2. If you have not installed a switch the two terminals must be bridged
OVERLOAD led on	24V power supply to accessories overload	<ol style="list-style-type: none"> <li>1. Remove the terminal block H1-H8: the OVERLOAD LED turns off</li> <li>2. Solve the problem causing overloading (terminals E1-E3)</li> <li>3. Re-install the terminal board and make sure the LED does not turn on again</li> </ol>
Extended pre-flashing time of the BLINKER	When a start command is given the blinker immediately turns up, but the gate does not open immediately: the count of cycles set for Service has expired	Enter the menu of the counters and reset the Service parameter
The display shows ERR1	Software error	Send the unit to the service department
The display shows ERR2	Faulty inverter	Check that the motor is connected properly. If the error persists send the unit to the Service department
The display shows ERR3	The functionality test of the photocells failed	<ol style="list-style-type: none"> <li>1. Make sure there are no obstructions between the photocells</li> <li>2. Check that the photocells enabled by menu are actually installed and working</li> <li>3. If type 2 photocells are used, make sure that the menu item FOT2 is set to CFCH</li> <li>4. Check out the preceding conditions, if the error persists, increase the time of the test (parameter FT.TE)</li> </ol>
The display shows ERR4	Limit switch error	Check that the limit switches are properly connected and that the limit switches are activated at the movement of the gate
The display shows ERR5	The function test of safety ribbons failed	<ol style="list-style-type: none"> <li>1. Make sure that the safety ribbons enabled by menu are actually installed and working</li> <li>2. Ensure that the control unit of the safety ribbons is properly connected and working</li> </ol>
The display shows ERR6	Faulty communication with the inverter	If the error persists send the unit to the Service department
The display shows ERR9	Access to the programming menu locked by CL1+	Insert the CL1+ module with which the programming was locked into the ADI connector: the unit will automatically enter the programming menu PRG
The display shows ERR10	The function test of the safety devices connected to the interface ADI failed	Verify that the ADI module is connected. Check that the safety devices connected to the ADI interface are properly connected and working
The display shows ERR12	Inverter overheating	The warning sign appears when the motor is stopped due to an overheating of the inverter that drives the motor and is repeated at each start command until the inverter finally cools down
The display shows INIT	Charging inverter	Before starting the motor, wait until the warning sign goes off
The display shows HALT	Emergency stop enabled	Turn off the STOP button between terminals T1 and T2. If you have not installed a switch the two terminals must be bridged

## 24 - TESTING AND START-UP

In implementing the automation device, these are the most important steps for guaranteeing maximum safety.

V2 recommends the application of the following technical standards:

- EN 12445 (Safety in the use of automated closures, test methods)
- EN 12453 (Safety in the use of automated closures, requirements)
- EN 60204-1 (Safety of Machinery, electrical equipment of machines, part 1: general principles)

In particular, with reference to the table in the section "PRELIMINARY CHECKS and IDENTIFICATION OF THE TYPE OF USE" in the majority of cases, it will be necessary to measure the impact force, in accordance with the provisions of EN 12445.

Adjusting the operating force is possible by programming the electronic circuit board, and the impact force profile should be measured using an appropriate device (itself also certified and subjected to annual calibration) capable of tracing the force-time graph.

The result should be in compliance with the following maximum values:

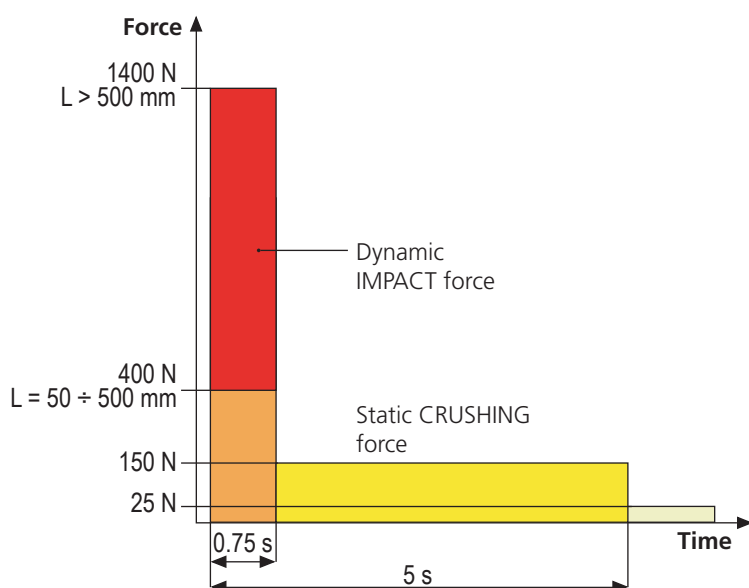

## 25 - MAINTENANCE

Maintenance should be performed in full compliance with the safety instructions described in this manual and in accordance with current legal and regulatory provisions. The recommended interval between each maintenance operation is six months, the checks involved should at least relate to:

- the perfect efficiency of all warning devices
- the perfect efficiency of all safety devices
- measurement of the gate operating forces
- the lubrication of mechanical parts on the automation device (where necessary)
- the state of wear of the mechanical parts on the automation device
- the state of wear of the electrical cables on the electromechanical actuators

The result of each check should be recorded in a gate maintenance log.



## 26 - DISPOSAL OF THE PRODUCT

As for the installation operations, even at the end of this product's life span, the dismantling operations must be carried out by qualified experts.

This product is made up of various types of materials: some can be recycled while others need to be disposed of. Find out about the recycling or disposal systems envisaged by your local regulations for this product category.

**Important!** – Parts of the product could contain pollutants or hazardous substances which, if released into the environment, could cause harmful effects to the environment itself as well as to human health. As indicated by the symbol opposite, throwing away this product as domestic waste is strictly forbidden. So dispose of it as differentiated waste, in accordance with your local regulations, or return the product to the retailer when you purchase a new equivalent product.

**Important!** – the local applicable regulations may envisage heavy sanctions in the event of illegal disposal of this product.



# AUTOMATION DEVICE USERS MANUAL

## AUTOMATION DEVICE USER INFORMATION

An automation system is a great convenience, in addition to a valid security system, and with just a little, simple care, it is made to last for years.

Even if your automation device meets all the safety standards, this does not exclude the presence of residual risk, i.e. the possibility that hazardous situations may be created, usually due to irresponsible or even improper use, and for this reason we wish to offer some advice regarding the behaviour to be adopted in order to avoid problems:

**Prior to using the automation device for the first time**, ask the installer to explain the sources of residual risk to you, and take some time to read the instruction manual and user information delivered by the installer.  
Keep the manual for any future doubts and give it to any new owners of the device.

**Your automation device is a machine that faithfully follows your commands**; irresponsible and improper use can make it become hazardous: do not start movement of the device if there are people, animals or objects within its radius of action.

**Children**: installed in accordance with technical regulations, an automation system guarantees a high level of safety. However, it is prudent to prevent children from playing near the automation device and to avoid unintentional use; never leave the remote control within the reach of children: it is not a toy!

**Anomalies**: as soon as the automation device shows any anomalous behaviour, remove the electricity supply and perform manual unblocking. Do not attempt any repairs yourself, but ask your installer: in the meantime, the system can operate as a non-automated device.

**Maintenance**: as with all machinery, your automation devices requires periodic maintenance so that it may continue to work for as long as possible, and in complete safety. Agree a periodic maintenance plan with your installer; V2 SpA recommends a maintenance plan to be performed every 6 months for normal domestic use, but this period may vary depending on the intensity of use. Any inspection, maintenance or repairs should only be performed by qualified personnel. Even if you think you know how, do not modify the system and the automation device programming and adjustment parameters: your installer is responsible for this. Final testing, periodic maintenance and any repairs should be documented by those performing the operations, and the documents held by the system owner.

**Disposal**: on completion of the device's operating life, ensure that disposal is performed by qualified personnel and that the materials are recycled or disposed of in accordance with valid local regulations.

**Important**: If your device is fitted with a radio control, the function of which appears to deteriorate over time, or has even ceased to function, this might simply depend on the batteries being run down (depending on the type, this may be from several months to up to two/three years). Before contacting your installer, try replacing the battery with the battery from another, working transmitter: if this was the cause of the problem, then simply replace the battery with another of the same type.

**Are you satisfied?** Should you wish to add another automation device to your home, contact the same installer and ask for a V2 SpA product: we guarantee you the most advanced products on the market and maximum compatibility with existing automation devices. Thank you for having read these recommendations, and for any present or future needs, we ask you to contact your installer in full confidence.

## MOTOR OVERRIDING SYSTEM

In the absence of power, the gate can be released by operating on the motor:

1. Open the rear hatch
2. Screw anti-clockwise (left thread) the ring nut **K** using the supplied 19" wrench until the pinion is released

To restart the automation proceed as follows:

1. Screw clockwise (left thread) the ring nut **K** up to the limit given by screw **L**
2. Close the rear hatch

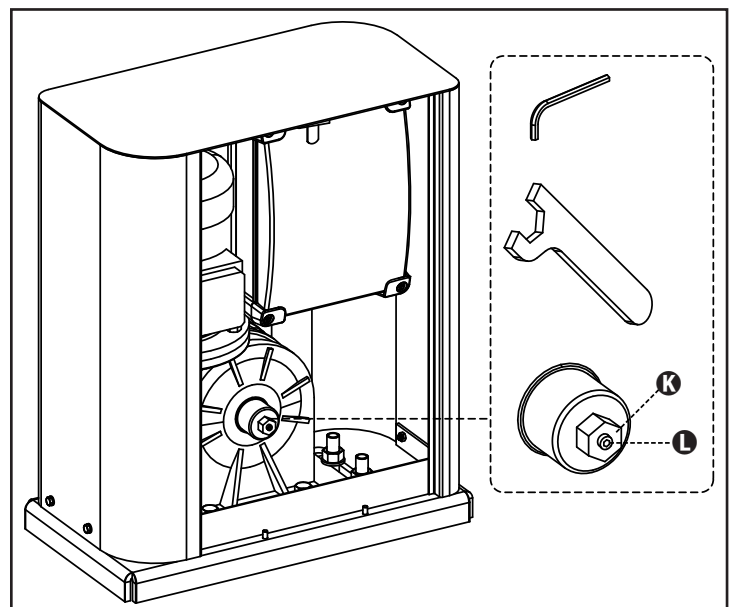



**V2 S.p.A.**

Corso Principi di Piemonte 65/67  
12035 RACCONIGI CN (ITALY)  
Tel. +39 0172 812411 - Fax +39 0172 84050  
info@v2home.com

**[www.v2home.com](http://www.v2home.com)**