

# DOMESTIC AND LIGHT-INDUSTRIAL SLIDING GATE OPERATORS

# **Company Profile**

---

Centurion Systems (Pty) Ltd, South Africa, has been manufacturing automatic gate systems since 1986, and is committed to providing reliable, cost-effective solutions in the field of gate and access automation.

We offer a diverse range of products including gate motors, GSM-based products, garage door motors, remote controls, keypads, traffic barriers, proximity access control and intercom systems.

Our products are developed by an in-house team of talented engineers that are constantly researching new and innovative technologies to improve our existing products and expand our product range.

Our production facility in Johannesburg is ISO:9001 quality assurance certified, and all our products are manufactured to the highest level of quality with a 100% test to specification.

Through a team of dedicated technicians and sales personnel, together with a fully fledged in-house training facility, we are committed to providing unmatched service to our customers and support for our products.

A worldwide network of distributors and installers ensure that our products remain The Automatic Choice in access automation .

Further information is available on our website [www.centsys.com](http://www.centsys.com)



Centurion Systems (Pty) Ltd reserves the right to make changes to the products described in this document without notice and without obligation of Centurion Systems (Pty) Ltd to notify any persons of any such revisions or changes. Additionally, Centurion Systems (Pty) Ltd makes no representations or warranties with respect to this document.

No part of this document may be copied, stored in a retrieval system or transmitted in any form or by any means electronic, mechanical, optical or photographic, without the express prior written consent of Centurion Systems (Pty) Ltd.

# Table of Contents

---

Declaration of Conformity . . . . .	4
Important Safety Instructions . . . . .	5
Fast Track . . . . .	6
General Description . . . . .	8
Specifications . . . . .	9
Product Identification . . . . .	11
Site Requirements . . . . .	12
Site Considerations . . . . .	14
Required Tools & Equipment . . . . .	14
Cabling Requirements . . . . .	15
Lubrication . . . . .	16
Operator Installation . . . . .	17
Locate Operator Position . . . . .	17
Route Cables and Secure Base Plate . . . . .	18
Mount the Operator . . . . .	19
Mount the Rack . . . . .	20
Mount the origin Marker . . . . .	22
Electrical Set-up . . . . .	24
Connect all Wiring . . . . .	24
Get into Programming Mode . . . . .	24
Set the Gate Limits (Automatic Set-Up Routine) . . . . .	24
Exit Programming Mode . . . . .	27
Check Gate Operation . . . . .	27
Setting Additional Features (Optional) . . . . .	27
Controller Programmable Features . . . . .	29
Controller Terminal Features . . . . .	31
Procedure to Programme Controller Back to Factory Default Settings . . . . .	32
Set-Up Troubleshooting Guide . . . . .	33
Fault Finding Guide . . . . .	35
CP80 Power Connections . . . . .	40
CP80 Signal Connections . . . . .	41
CP84 Charger Connection (Standard and Low Voltage) . . . . .	42
CP84XTE Charger Connections . . . . .	42
PSUx Power Connection . . . . .	42
Recommended Earthing for Effective Lightning Protection . . . . .	43
CP80 Controller Features . . . . .	44
LED Indicator Lights . . . . .	45
Installation Handover . . . . .	46

# Declaration of Conformity

---

**Manufacturer:** Centurion Systems (Pty) Ltd  
Unit 13, Northlands Production Park  
Epsom Avenue  
Northriding

**Declares that the product:**

Product Name: D3 / D5 Sliding Gate Operator  
Product Options: All variants

**Conforms with the following specifications:**

Safety: IEC 60355-1:1991 & Am1:1994 & Am2:1999

**For D3:**

EN 12453:2000 EN 12978:2003 when fitted with CE chip and a P36 Passive Sensitive Edge according to instructions.

Emissions: CISPR 14: 2nd edition 1985

CISPR 22 CLASS B: RADIATED EMISSIONS - 30MHZ TO 1000MHZ

CISPR 22 CLASS B: CONDUCTED EMISSIONS - 150MHZ TO 30MHZ

Immunity:

IEC 801-2: 2nd edition 1991 - 4kV CD, 8kV AD

IEC 801-3: 1st edition 1984 - 10V/m

IEC 801-4: 1st edition 1988 - 1.0kC Power Lines

IEC 1000-3-2: 1997

IEC 1000-3-3: 1997

IEC 1000-4-5: 1997

IEC 61000-4-2 - ELECTROSTATIC DISCHARGE

IEC 61000-4-3 - RADIATED IMMUNITY - 80MHZ TO 1000MHZ

IEC 61000-4-4 - ELECTRICAL FAST TRANSIENTS / BURST

IEC 61000-4-5 - SURGE IMMUNITY TEST

IEC 61000-4-6 - CONDUCTED IMMUNITY - 150KHZ TO 80MHZ

IEC 61000-4-11 - VOLTAGE DIPS AND INTERRUPTION

Supply Information: The product herewith complies with the requirements for the following directives and carries the CE-marking accordingly.

- the Low Voltage Directive 73/23/EEC

- the EMC Directive 89/336/EEC (inclusive 93/68/EEC)]

This product was tested in a typical configuration with simulated gate load.

**Standard to which conformity is declared:**

IEC 60355-1:1991 & Am1: 1994 & Am2: 1999

IEC 1000-6-3 & IEC 1000-6-1: Generic Emission and Immunity

Signed at North Riding, South Africa on 15 August, 2005



Ian Rozowsky  
Research & Development Director

# Important Safety Instructions

## **⚠ ATTENTION**

To ensure the safety of people, it is important that you read all the following instructions. Incorrect installation or incorrect use of the product could cause serious harm to people.

The installer, being either professional or DIY, is the last person on the site that can ensure that the operator is safely installed, and that the whole system can be operated safely.

## WARNINGS FOR THE INSTALLER

1. CAREFULLY READ AND FOLLOW ALL INSTRUCTIONS before beginning to install the product.
2. All installation, repair, and service work to this product must be done by a suitably qualified person.
3. Do not activate your gate opener unless you can see it and can determine that its area of travel is clear of people, pets, or other obstructions.
4. NO ONE MAY CROSS THE PATH OF A MOVING GATE. Always keep people and objects away from the gate and its area of travel.
5. NEVER LET CHILDREN OPERATE OR PLAY WITH THE GATE CONTROLS, and do not allow children or pets near the gate area.
6. Secure all easily accessed gate opener controls in order to prevent unauthorized use of the gate.
7. Do not in any way modify the components of the automated system.
8. Do not install the equipment in an explosive atmosphere: the presence of flammable gas or fumes is a serious danger to safety.
9. Before attempting any work on the system, cut electrical power and disconnect the batteries.
10. The mains power supply of the automated system must be fitted with an all-pole switch with contact opening distance of 3mm or greater. Use of a 5A thermal breaker with all-pole circuit break is recommended.
11. Make sure that an earth leakage circuit breaker with a threshold of 30mA is fitted upstream of the system.
12. Never short circuit the battery and do not try to recharge the batteries with power supply units other than that supplied with the product, or by Centurion Systems.
13. Make sure that the earthing system is correctly constructed, and that all metal parts of the system are suitably earthed.
14. Safety devices must be fitted to the installation to guard against mechanical movement risks such as crushing, dragging and shearing.
15. It is recommended that at least one warning indicator light be fitted to every system.
16. Always fit the warning signs visibly to the inside and outside of the gate.
17. The installer must explain and demonstrate the manual operation of the gate in case of an emergency, and must hand the User/Warnings guide over to the user.
18. Explain these safety instructions to all persons authorized to use this gate, and be sure that they understand the hazards associated with automated gates.
19. Do not leave packing materials (plastic, polystyrene, etc.) within reach of children as such materials are potential sources of danger.
20. Dispose of all waste products like packaging materials, worn out batteries, etc, according to local regulations.
21. **Always check** the obstruction detection system, and safety devices for correct operation.
22. Centurion Systems does not accept any liability caused by improper use of the product, or for use other than that for which the automated system was intended.
23. This product was designed and built strictly for the use indicated in this documentation. Any other use, not expressly indicated here, could compromise the service life/operation of the product and/or be a source of danger.
24. Everything not expressly specified in these instructions is not permitted.

## **⚠ WARNING**



### **MOVING GATE CAN CAUSE SERIOUS INJURY OR DEATH**

KEEP CLEAR. GATE MAY MOVE AT ANY TIME. DO NOT ALLOW CHILDREN TO PLAY IN AREA OR OPERATE GATE .

These abbreviated instructions are for the experienced installer who needs a checklist to get a standard installation up and running in the minimum of time.

Detailed installation features and functions are referred to later in this manual.

## Mechanical Setup

### Action

<b>Step 1</b>	<b>Read and understand all safety instructions</b>	<b>Page 5</b>
<b>Step 2</b>	<b>Check site requirements</b>	<b>Page 12</b>
<b>Step 3</b>	<b>Heed necessary site considerations</b>	<b>Page 14</b>
<b>Step 4</b>	<b>Gather required tools and equipment</b>	<b>Page 14</b>
<b>Step 5</b>	<b>Check cabling requirements</b>	<b>Page 15</b>
<b>Step 6</b>	<b>Lubrication requirements</b>	<b>Page 16</b>
<b>Step 7</b>	<b>Select method of mounting and operator position</b>	<b>Page 17</b>
<b>Step 8</b>	<b>Route required cabling</b>	<b>Page 18</b>
<b>Step 9</b>	<b>Mount the operator</b>	<b>Page 19</b>
<b>Step 10</b>	<b>Mount the rack</b>	<b>Page 20</b>
<b>Step 11</b>	<b>Mount the origin marker</b>	<b>Page 22</b>
	<b>Apply warning decals</b>	<b>Page 23</b>

**Electrical Setup***Action*

<b>Step 1</b>	<b>Read and understand all safety instructions</b>	<b>Page 5</b>
<b>Step 2</b>	<b>Connect all wiring:</b>	<b>Page 24</b>
<b>Step 3</b>	<b>Get into programming mode:</b> Remove all power. <ul style="list-style-type: none"><li>• Fit the SET link.</li><li>• Reapply power.</li></ul>	<b>Page 24</b>
<b>Step 4</b>	<b>Set the gate limits:</b> Move gate half way and engage. <ul style="list-style-type: none"><li>• Press and hold TEST, release after 1 flash of L1.</li><li>• Press and hold TEST, release after 1 flash of STATUS.</li><li>• Check that gate will travel in the correct direction.</li></ul>	
<b>Step 5</b>	<b>Exit programming mode:</b> <ul style="list-style-type: none"><li>• Remove the SET link.</li></ul>	<b>Page 27</b>
<b>Step 6</b>	<b>Check gate operation</b>	
<b>Step 6</b>	<b>Perform installation hand over</b>	<b>Page 46</b>



When fault finding an existing installation, refer to the FAULT FINDING GUIDE on page 35

# General Description

---

The D3 and D5 are sliding gate operators designed to open and close sliding gates.

The D3 operator is suited to domestic applications with gates of a mass less than 300kg.

The D5 operator is suited to domestic applications with gates of a mass less than 500kg.

In order to cater for high duty cycle installations, the D5 Light Industrial model is offered. The D5 Light Industrial model is similar to the Standard D5 model with the exception that it is rated for a higher duty cycle. It is suitable for sites with a gate mass up to 500kg, but can operate with a 50% duty cycle.

Gate travel limits are managed by an opto-electronic system, comprising a gate mounted origin marker and an internal rotary encoder. This system yields precise and repeatable control over gate position.

In cases where chain, (as opposed to toothed rack) drive is required, an optional chain drive kit is available.

Advanced features of the CP80 logic controller include:-

- Automated setup of gate endpoints (limits).
- Fail safe collision detection and auto reverse (adjustable sensitivity).
- Smoothed start/stop (ramp up/down).
- Multiple operational modes.
- Selectable, adjustable auto-closing.
- Pedestrian (partial) opening.
- Positive Close Mode.
- Safety input for sensitive edge/safety beam/inductive loop.
- Advanced lightning/surge protection.
- Timed courtesy light output.
- Multiple preflashing modes.

## Lightning Protection

The D5 electronic controller utilizes the same proven surge protection philosophy that is used in all Centurion products. While this does not guarantee that the unit will not be damaged in the event of a lightning strike or power surge, it greatly reduces the likelihood of such damage occurring. The earth return for the surge protection is provided via the mains power supply earth. In order to ensure that the surge protection is effective, it is essential that the unit is properly earthed.



# Specifications

## Overall Dimensions

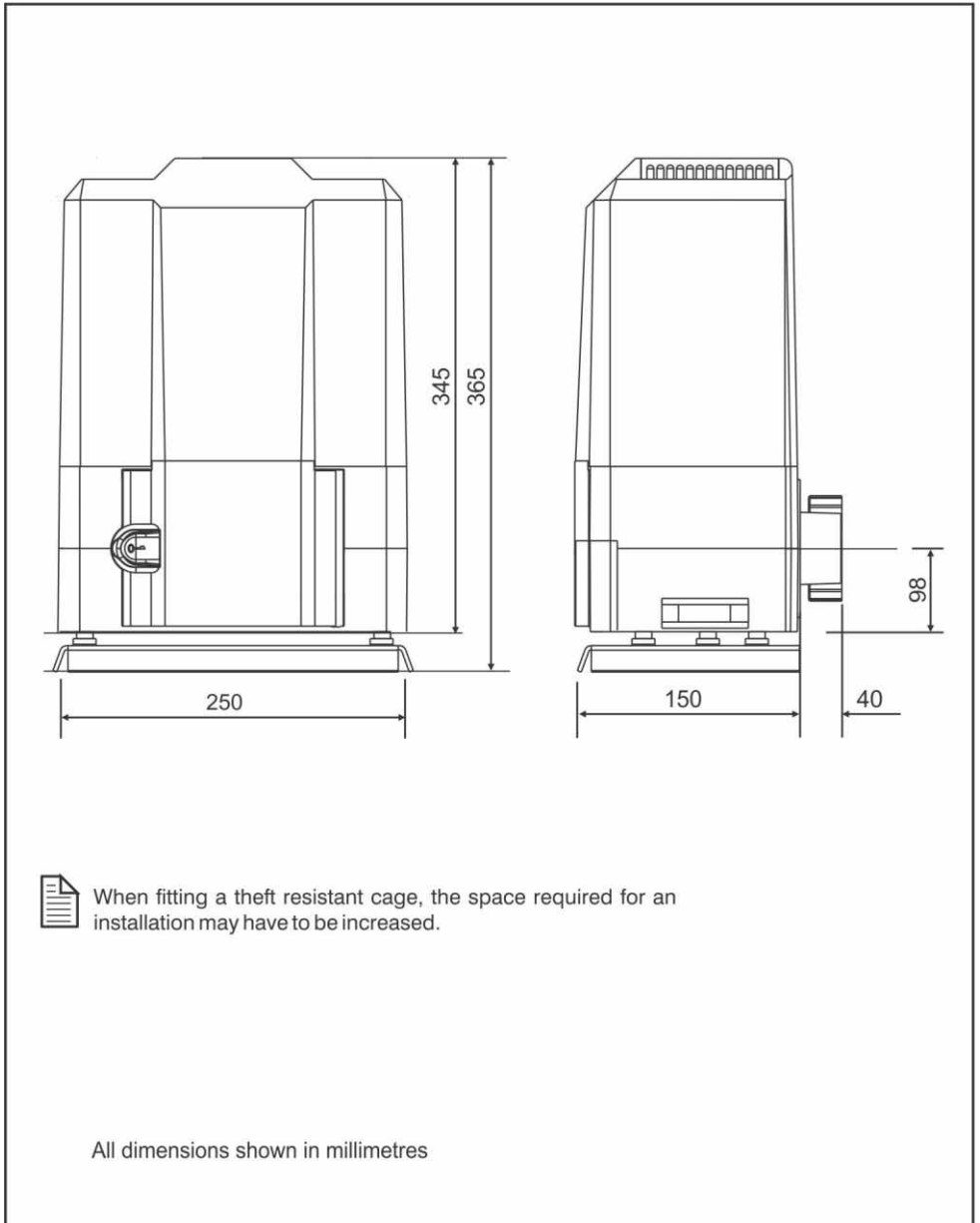

When fitting a theft resistant cage, the space required for an installation may have to be increased.

All dimensions shown in millimetres

Figure 1 Overall Dimensions

<b>SPECIFICATIONS</b>	<b>D3</b>	<b>D5</b>
Power Supply Voltage (Depending on power supply used)	220V AC $\pm$ 10% 50Hz 110V AC $\pm$ 10% 50Hz 19V AC $\pm$ 10% 50Hz	220V AC $\pm$ 10% 50Hz 110V AC $\pm$ 10% 50Hz 19V AC $\pm$ 10% 50Hz
Motor Voltage	12V DC	12V DC
AC Current draw @ 220V	120mA	120mA
DC Current draw (Max)	15A	15A
Output shaft rotational speed	73rpm	91rpm
Rated Gate Speed (With gate pull force <5kg)	16m/min	20m/min
Starting Thrust	35kgF	60kgF
Rated Thrust	12kgF	20kgF
Maximum gate mass	300kg	500kg
Maximum gate length	11m	11m
Maximum number of operations per day (Average) Mains Present:		
Battery driven (1A charger, 7Ah battery)	20	50
Battery driven (2A charger, 7Ah battery)	30	150
Power pack (10A power pack, no battery)	N/A	100
Standby;		
With 7Ah Battery	12	10
With 40Ah Battery	N/A	100
Maximum number of continuous operations per hour (Mains Present)		
Battery driven (1A charge, 7Ah battery)	10	10
Battery driven (2A charger, 7Ah battery)	30	30
Power pack (10A power pack, no battery)	N/A	20
Typical time to open/close a 4m gate	17 seconds	13 seconds
End of travel control	Sealed optical counter with origin switch	Sealed optical counter with origin switch
Collision sensitivity	Electronic, adjustable	Electronic, adjustable
Temperature range	-10° to +50°C	-10° to +50°C
Housing protection	IP55	IP55
Control card *	CP80	CP80
Corrosion protection (baseplate)	Zincroshield	Zincroshield
Mass of unit (packed) including 7,5Ah Battery	12kg	13.5kg
* D3 and D5 have different micro-controller versions		

# Product Identification

The actual components supplied may vary depending on the model purchased.

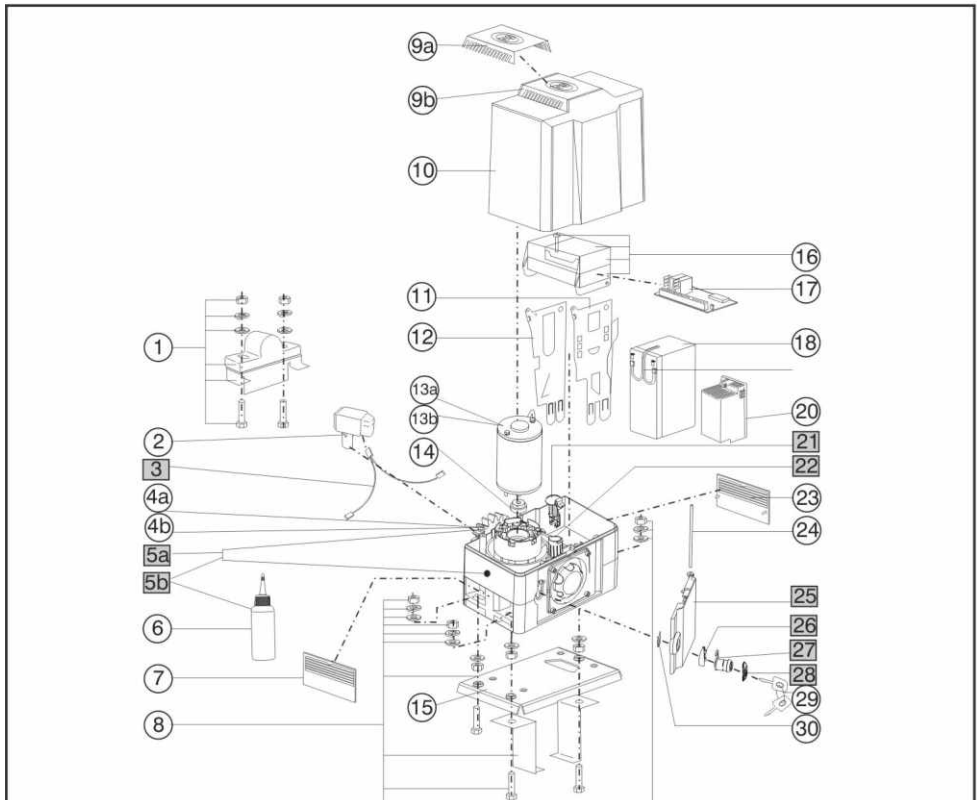

Item No.	Part No.	Description	Item No.	Part No.	Description
1	1099SUB008	D3/5 Gate Origin Magnet Mounting Kit	14	1099300700	D3 Drive Coupling (Motor Side)
2	1099SUB7N2	D5 Magnetic Switch Assembly	15	1010260000	Mounting Plate D5
3	WHD5DOSSV3	Wiring Harness DOSS & Sensor Plug	16	10103701AS	CP80 Enclosure
4a	101007GKNO	17T Mod 4 Sintered Pinion S5 Sliders	17	CP80	CP80 PC Board (Boxed)
4b	1099070001	D3 17T Nylon 66 Pinion 8mm Radial Pin	18	CP4	CP4 Battery
5a	1099SUB15A	D3 Gearbox Casing & Gear set Assembly	19	WHHCen-BAT	D5 Battery Leads
5b	1010SUB15A	D5 Gearbox Casing & Gear set Assembly	20	CP84E	CP84E Power Supply (Boxed)
6	OIL80MLOX0/H	Gearbox Oil	21	1099SUB03A	DOSS Carrier Assembly (Includes harness)
7	1010200000	Side Cover (Vertical) D5	22	1010M11490	DOSS Mounting Tube
8	1099SUB009	CP25SR5 D5 Foundation Plate Assembly	23	1010230000	Side Cover (Horizontal) D5
9a	10102202D3	D3 Vent Cover (Logo)	24	1010250000	Sr5 Door Hinge Pin 4 x 127mm 304 SS
9b	10102202D5	D5 Vent Cover (Logo)	25	1010M10130	D5 Door V3 (Stiffened Lip)
10	1010220101	D5 Exterior Cover	26	1050M02210	Camlock Cover Base
11	1010290000	Support Bracket D5 Slider (DOSS Side)	27	MB44LA1107	19mm Camlock
12	1010280000	Support Bracket D5 Slider (Battery Side)	28	1050M02220	Camlock Cover
13a	MTDZY8000	D5 Motor, 12V DC 3200 RPM	29	D5KEY	Spare Key for D3/D5 Motors
13b	MTDZY8080	D3 Motor 12V DC 2700 RPM	30	SPRCLIPCLI	Camlock Spring Clip

Figure 2 Product Identification

# Site Requirements

## **⚠ WARNING**

Ensure that pedestrian gates which are built into the sliding gate can be secured in the closed position and are provided with at least a weatherproof normally closed safety switch that is connected to the IRB or LCK input of the control card.

## Starting Force

1. Test the starting force of the gate as per the diagram. Use a pull scale to determine a value(kgF) to get the gate into motion.
2. Determine the Running Force of the gate by continuing to pull on the scale with just sufficient force to keep it running and read off the maximum value (kgF) shown on the scale.
3. Where possible determine the gate mass.
4. Ensure that the Starting Force, Running Force and mass of gate are within the operating parameters shown in the table.

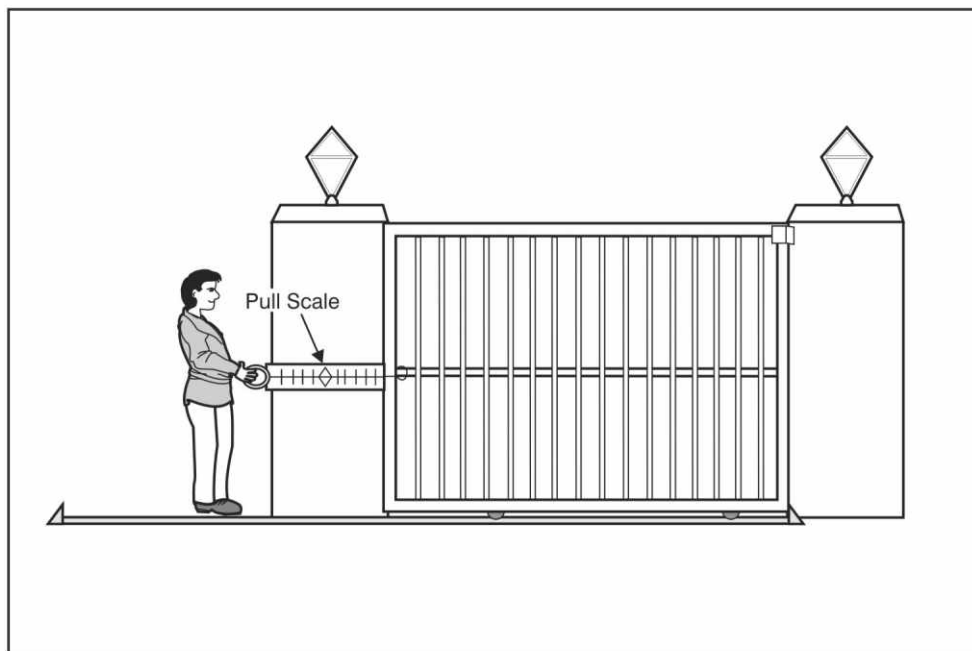

Figure 3 Starting and Running Forces

## End Stops

1. End stops are mandatory and must be fitted to prevent accidental injury or death should the gate overrun its limits for any reason.

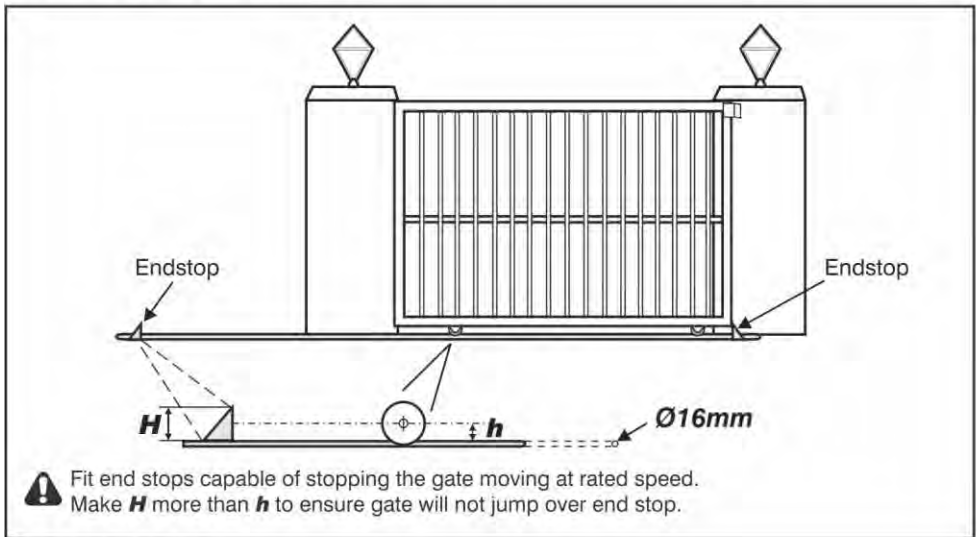

Figure 4 Gate End Stops

## Anti Lift Brackets

2. To prevent unauthorised access fit anti-lift brackets as shown.

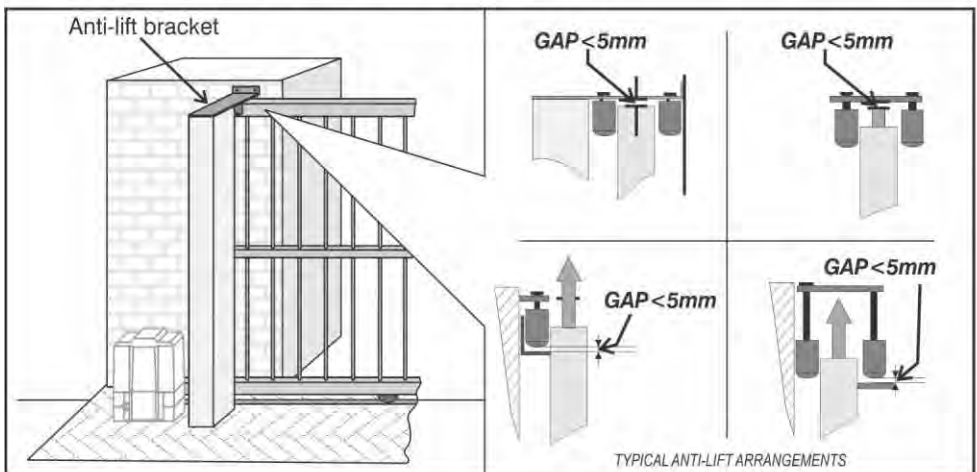

Figure 5 Anti Lift Brackets

# Site Considerations

## Install the gate operator only if:

1. It will not pose a hazard to the public.
2. There is sufficient clearance to a roadway and/or public thoroughfares.
3. The installation will meet all municipal and/or local authority requirements once completed.
4. The gate mass, pull force and application is within the operator specifications (see page 10).

## General considerations for the installation:

5. Always recommend the fitment of additional safety equipment such as safety edges and safety beams, for additional protection against entrapment or other mechanical risks.
6. Check that no pipes or electrical cables are in the way of the intended installation.
7. Check for loose sandy soil if installing foundations, as the soil condition may require a larger foundation.
8. Never fit the operator on the outside of the gate where the public has access to it.
9. Ensure there is sufficient drainage where the motor is located to guarantee that there is no water build-up around the operator.

# Required Tools & Equipment

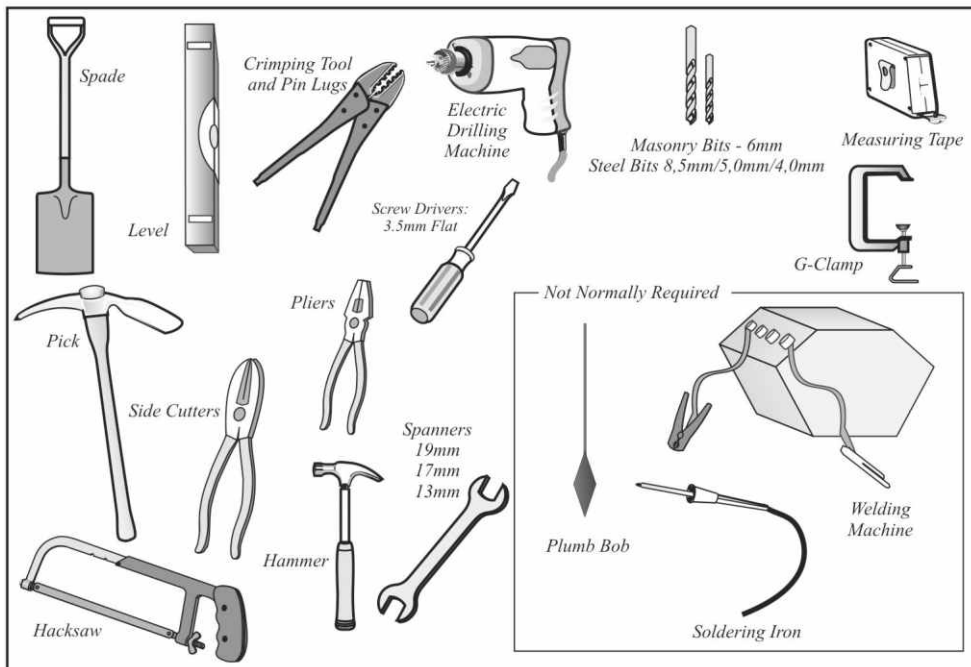

Figure 6 Required Tools and Equipment

# Cabling Requirements

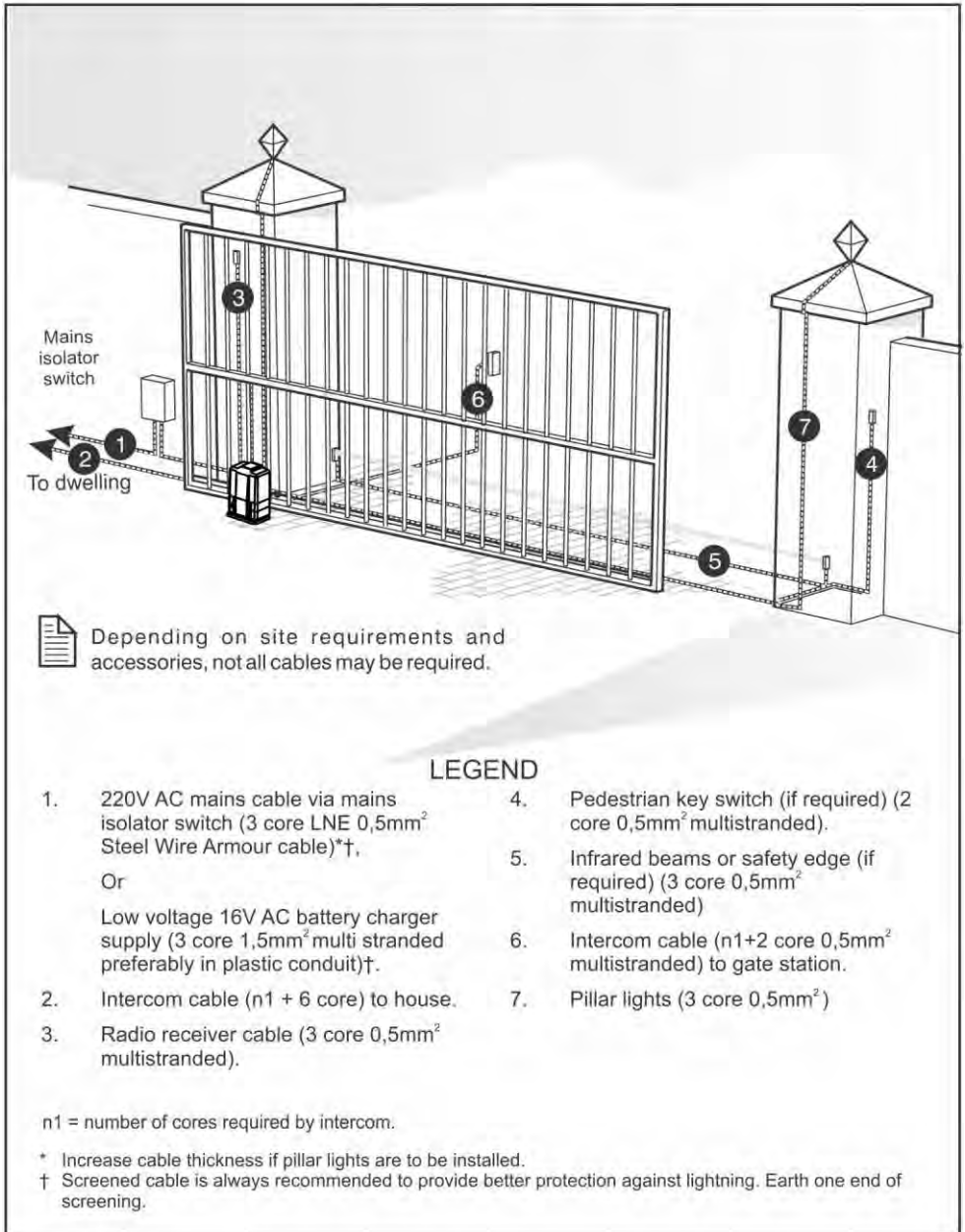

Figure 7 Cabling Requirements

# Lubrication

## ⚠ ATTENTION

In order to prevent possible leakage during shipping, the operator is **shipped with no oil inside the gearbox**. A bottle containing 80 ml of oil is included with the product, and this **MUST** be added **BEFORE** operating the product.

The operator does not require routine oil changes. However in the event of the unit losing oil due to stripping down or mechanical damage, the correct replacement oil is Centurion Systems product code: OIL80MLOX0/H.

If the gearbox is bolted down in the horizontal position during filling, the correct level is reached when the oil level is in the flat section of the dip stick. Emptying the 80ml bottle of oil provided will provide sufficient lubrication.

## ⚠ WARNING

**DO NOT ATTEMPT TO RUN THE OPERATOR WITHOUT FIRST FILLING THE GEARBOX WITH LUBRICANT.**

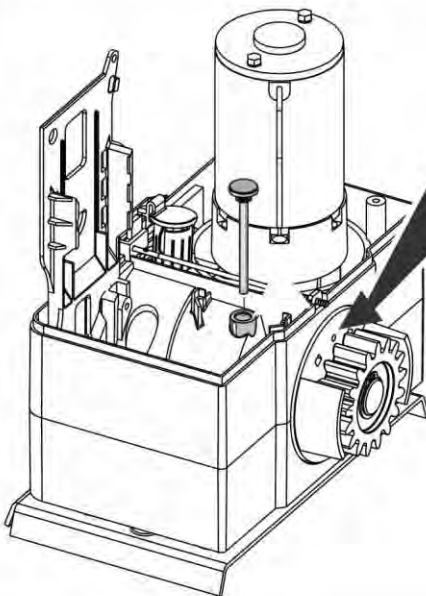

### Put Oil In Here

Oil Specifications:  
Centurion Systems  
product code: OIL80MLOX0/H  
Qty: 80ml

### Oil Filling Procedure

1. Lift the cover off the operator.
2. Remove the battery so that you can gain access to the **coloured** filler plug.
3. Remove the **coloured** oil filler plug by levering it out with a screwdriver.
4. Empty contents of this oil bottle into the gearbox.
5. Refit the **coloured** oil filler cap.

Upright detail removed for clarity.

Figure 8 Fill the Gearbox with Lubricant



# Operator Installation

## Locate operator position

1. To ensure operator does not protrude into driveway, install base plate at least flush with the driveway entrance.
2. Determine a suitable position and vertical height for the operator by considering Figures 9, and 10.



With careful selection of the rack configuration, and operator vertical height, mounting of the rack could in some cases be greatly simplified.



If a theft resistant cage is required, be sure to leave enough clearance from pillars etc.

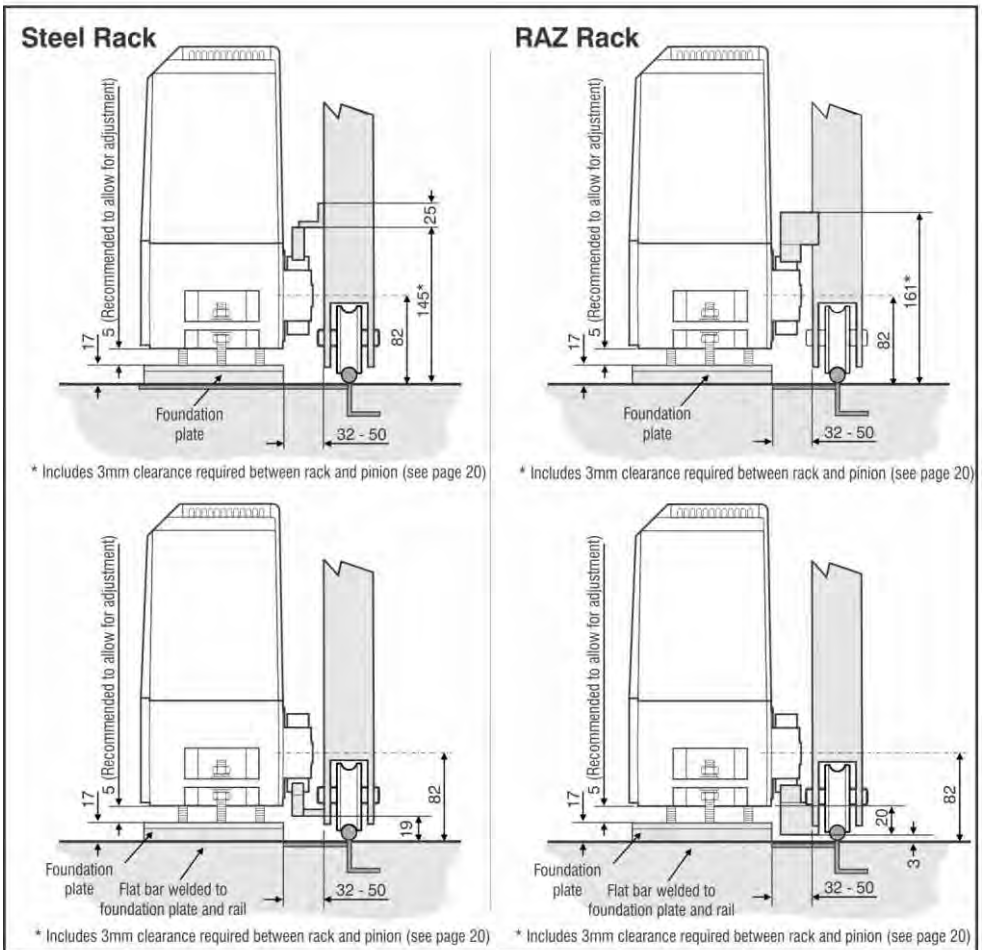

Figure 9 Operator Position

- Depending on the mounting method, either prepare a square hole for a concrete foundation, or drill holes for RAWL bolts as shown in Figure 10.



When using a concrete foundation it is recommended that the operator baseplate be welded to the track using a short length of flat bar. This makes it possible to complete the whole mechanical and electrical installation, without having to wait for the concrete to set. After completing the installation the concrete can be poured, and the operator left in manual mode until the concrete has set.

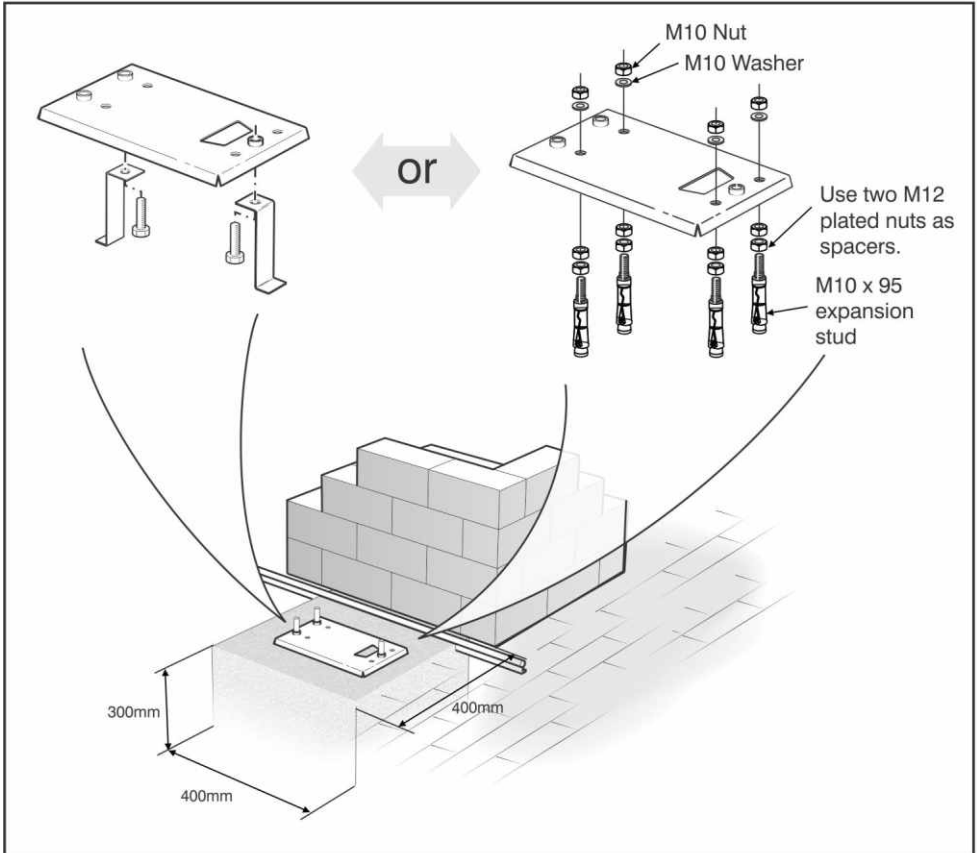

Figure 10 Foundation Plate Mounting

## Route cables and secure base plate:

- Route cables as determined in the cabling plan (Figure 7), making sure that all cables protrude at least 400mm above the baseplate once installed, as in Figure 11.
- Securely concrete or bolt the baseplate in position as shown in Figure 10.

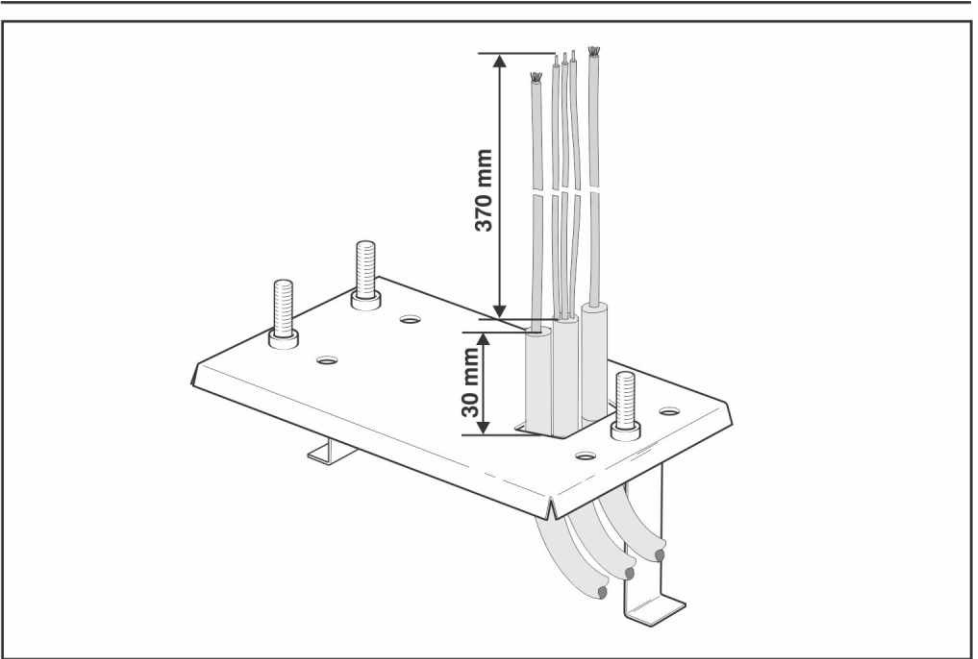

Figure 11 Route Cables Through Baseplate

### Mount the operator:

- 6. Fit M10 nuts and washers to the base as shown in Figure 12. Take care to adjust the nuts to be 7mm clear from the base to allow for later adjustment. NB: Remember to fit washers.

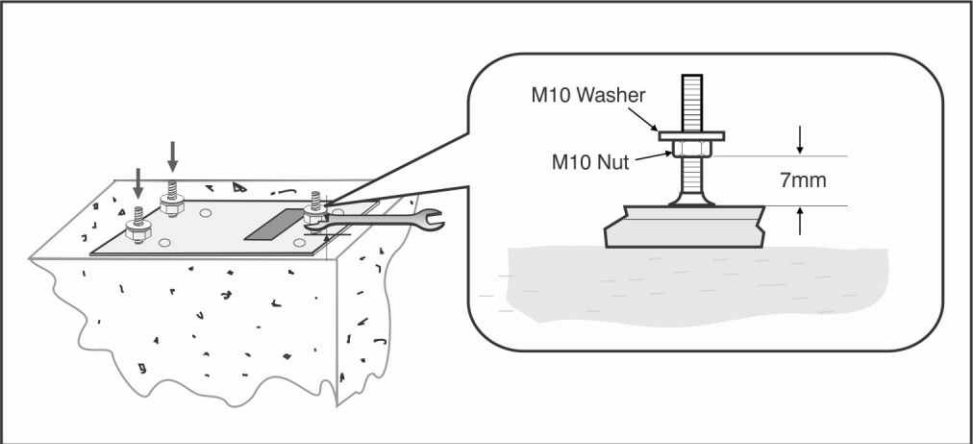

Figure 12 Prepare to Mount Operator

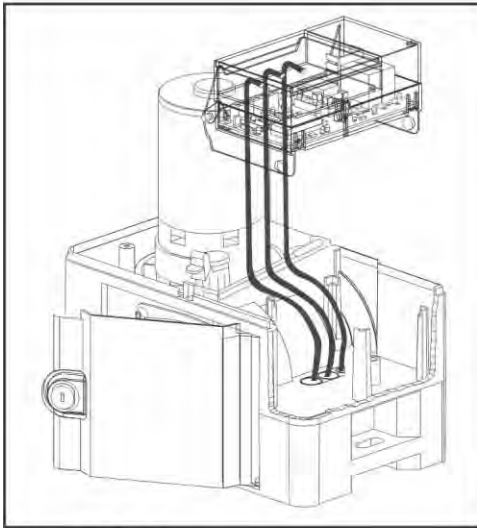

Figure 13 Cable Route

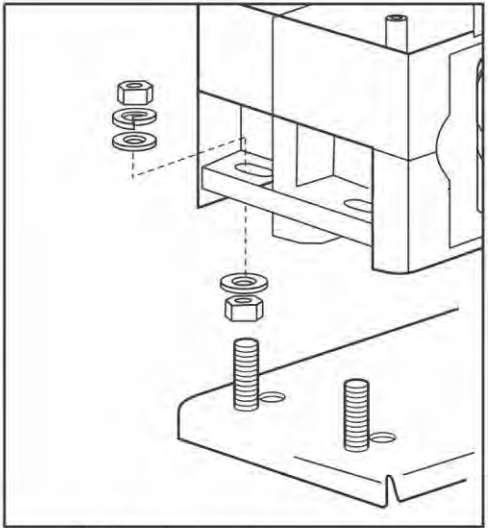

Figure 14 Secure the Operator

7. Remove the knock-outs from the gearbox and feed the cables through the holes, while fitting the gearbox to the base plate (Figure 13).
8. Secure the motor in place with 6 flat washers, 3 spring washers and 6 nuts supplied, as shown in Figure 14.
9. Seal the conduit and knock-out holes in the operator with silicone sealer to prevent ants from entering the operator.

## Mount the rack:

10. Before mounting the rack, **raise the motor an additional 3mm**. Place the first section of rack flush on the pinion and secure it to the gate. Continue to secure all sections of rack to the gate (see Figure 16). Once the entire rack is secured in place, **lower the operator 3mm** to ensure a vertical clearance between rack and pinion of 3mm. See Figure 15

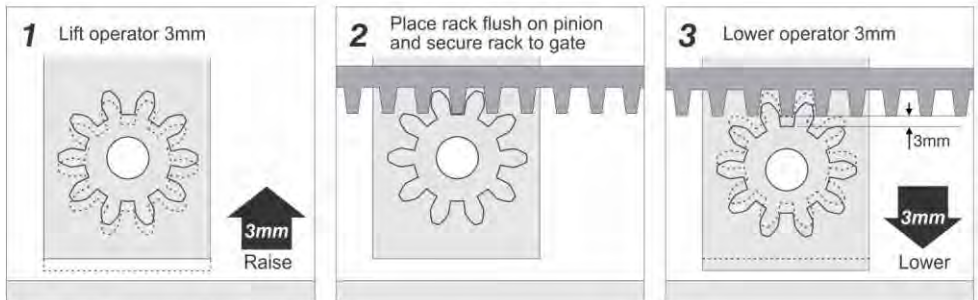
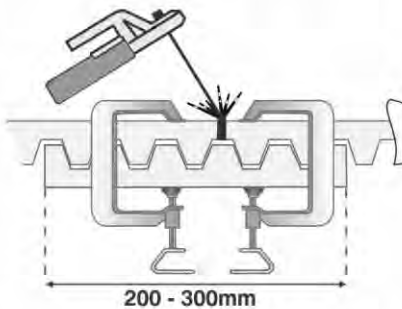
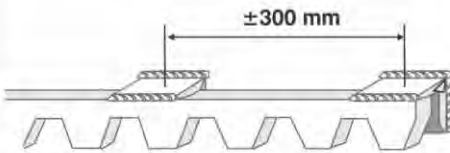
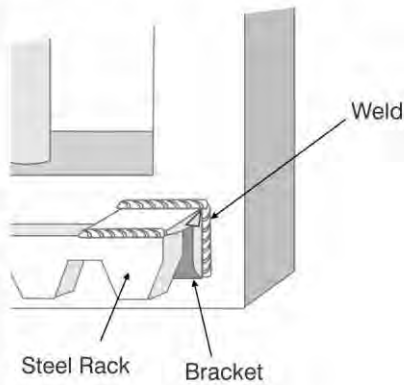

Figure 15 Preparation to Mounting Rack

## Steel Rack



When joining steel rack sections it is important to maintain the correct tooth spacing across the joint. This will ensure a reliable and quiet running gate.

Use a rack off-cut to clamp the 2 sections of rack together before welding. Be sure that weld does not foul the mesh surfaces.

## RAZ Rack

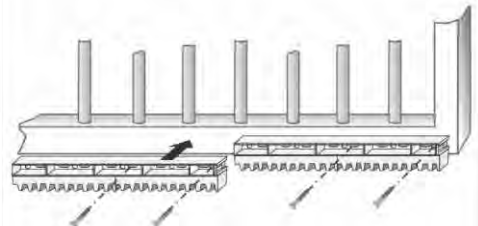
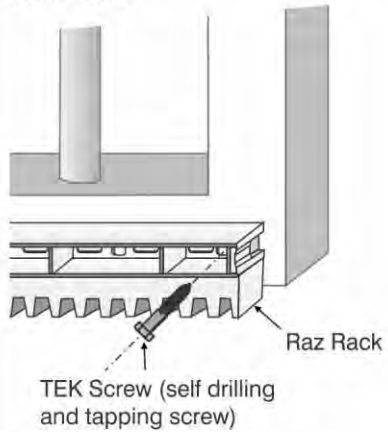

When fitting RAZ rack it is easier to **start on the right** and work towards the left.

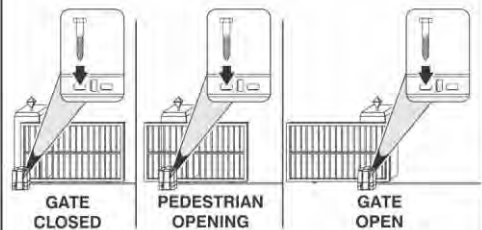

Fit additional fixing screws through horizontal slots to secure the rack to the gate directly above the operator pinion when the gate is in the closed, pedestrian, and open positions.

Figure 16 Rack Mounting

# Mount the origin marker:

11. Close the gate completely.
12. Mount the origin marker to the rack (Figure 18) at least 500mm from the origin sensor (Figure 19). If a CE chip is fitted to the control card (Figure 17), mount the origin marker at least 1000mm from the origin sensor to allow for the longer crawl distance.



If the crawl distance feature of the control card (page 44) has been changed from the default value of 1, the origin marker position must be **increased** by at least 250mm x crawl setting value.



The position of the origin marker affects how far the gate will open for the PEDESTRIAN opening feature. Locating the marker at a distance greater than the recommended distance will increase the pedestrian opening.

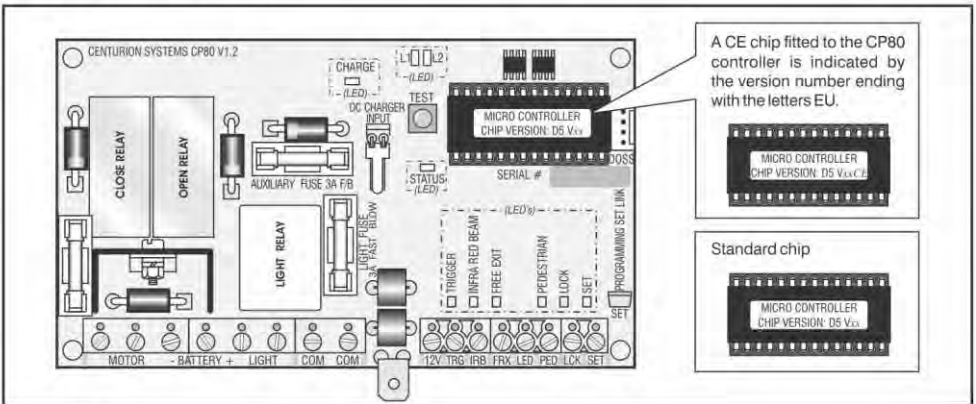

Figure 17 Chip Identification

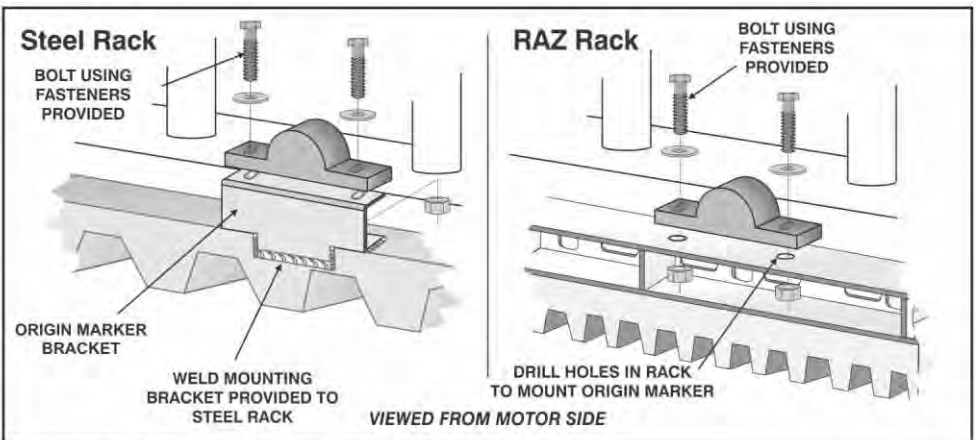

Figure 18 Mounting the Origin Marker

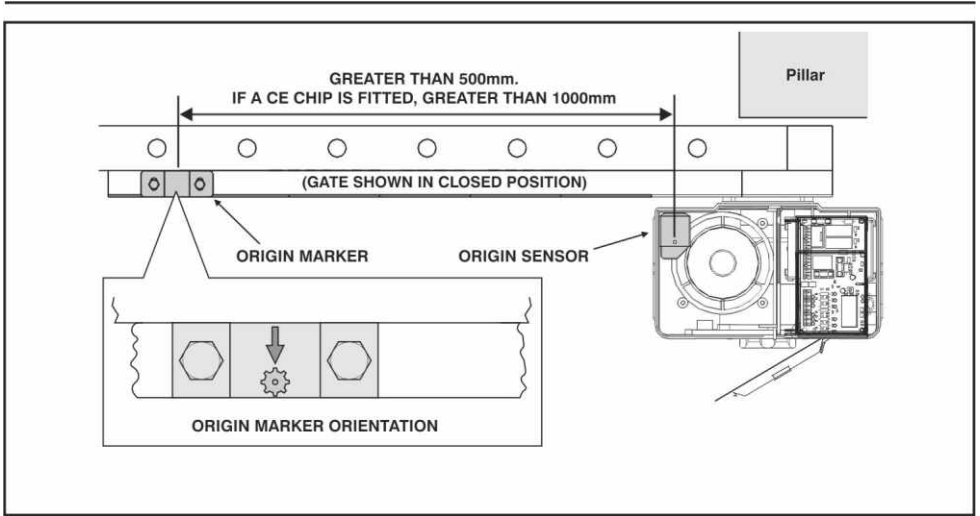

Figure 19 Origin marker Location

- Open the gate until the origin marker is in line with the origin sensor and adjust the clearance between the origin sensor and origin marker to between 5 and 10mm (Figure 20). For optimum performance, try and keep this distance as small as possible.

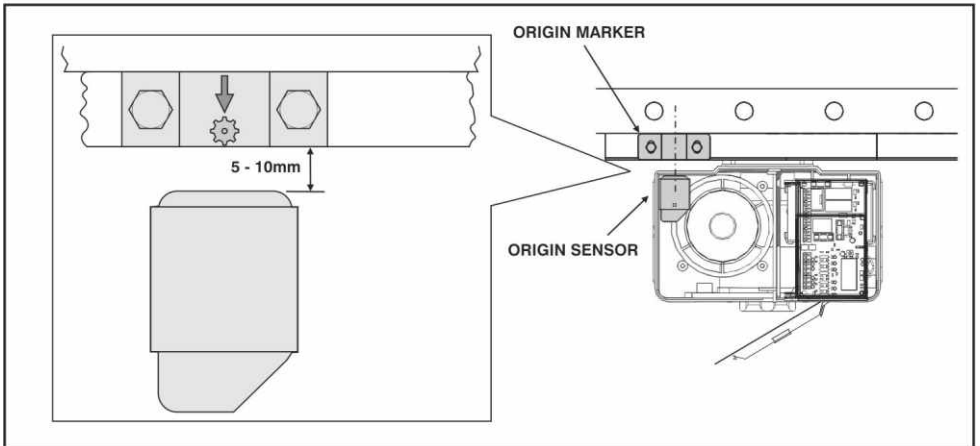

Figure 20 Origin Marker and Sensor Clearance

## Apply Warning Decal

- Apply the supplied warning decals to the gate as indicated on the reverse side of the decal.

# Electrical Set-up

## **⚠ WARNING**

1. Always check that the mains isolator in the electrical panel is in the OFF position, and that all high voltage circuits (more than 42.4V) are completely isolated from the mains supply before doing any work.
2. Ensure that all low voltage systems (Less than 42.4V) are suitably protected from damage, by disconnecting all sources of power such as chargers and batteries before doing any work.
3. All electrical work must be carried out according to the requirements of all applicable local electrical codes. (It is recommended that a licensed electrical contractor perform such work.)

## Connect all wiring

1. Connect all cables as required to the control card and battery charger, according to the wiring diagrams on page 40 - 43.

## Get into Programming Mode

2. Remove ALL power from the controller, i.e. charger plug and battery Figure 23.
3. Fit the SET link to the SET pins as shown in Figure 24.
4. Reapply power by connecting the charger plug, and then the battery to the controller.

Immediately after reconnecting the power, the STATUS light will flash 5 times. The SET and L2 lights will be on, L1 must be off to indicate you are now in programming mode. See Figure 23 and 24. ( See Setup troubleshooting Guide, page 33, step 4)

## Set the Gate Limits

5. Disengage the gearbox by manually rotating the manual release thumbwheel fully clockwise, or until clutch is fully disengaged and gate can be moved by hand. See Figure 21.
6. Slide gate approximately half way open. See Figure 22.
7. Re-engage gearbox by turning thumbwheel anti-clockwise and moving gate until an audible click is heard.
8. To set the gate limits **press and hold** the TEST button while monitoring LED L1 (see Figure 23).
9. When L1 flashes once, **release the TEST** pushbutton. L2 will go out, L1 will continue to flash once per second. (The controller is now ready to set the gate limits).
10. To start the Automatic Set-up Routine **press and hold the TEST** pushbutton until the STATUS light comes on, then **release the TEST** pushbutton. The Automatic Set-up Routine commences. ( See Setup troubleshooting Guide, page 33, step 10)



Figure 21 Rotate Manual Release Thumbwheel



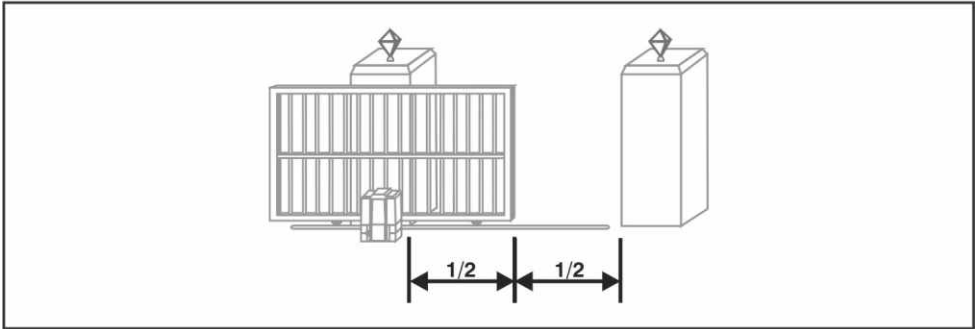

Figure 22 Slide gate approximately half way open

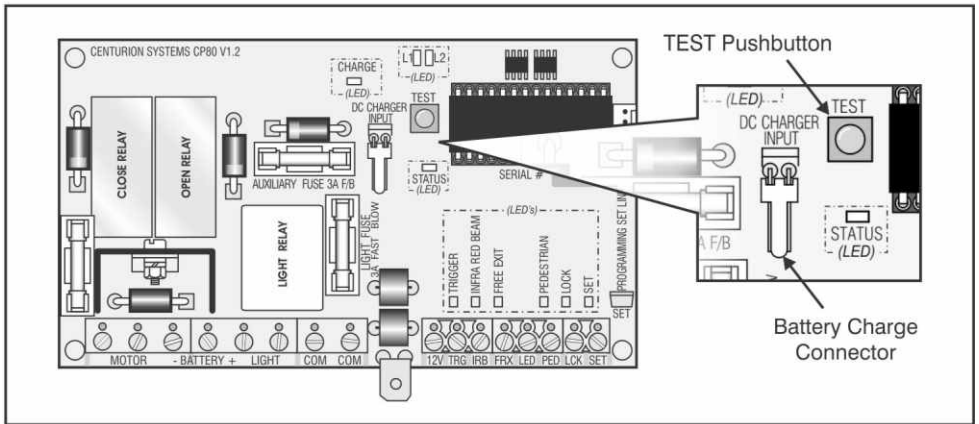

Figure 23 CP80 Test Pushbutton and Battery Connector Locations

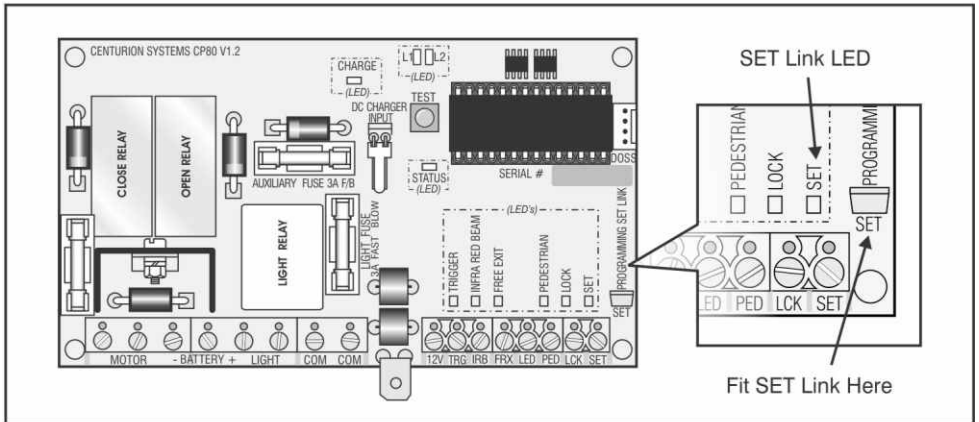
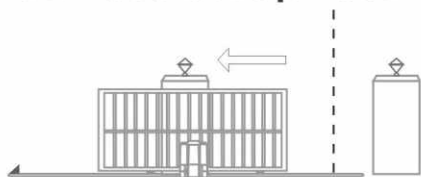

Figure 24 CP80 SET Link LED and Fitment Locations

## Automatic Set-up Routine



- 1** Gate starts at "crawl" speed to **open gate**.  
**NB.** If gate closes, remove power and reverse motor wires (see page 39) and restart the procedure from step 6.  
(*See Setup troubleshooting Guide, page 34, step 10.2*)



- 2** Gate hits "open" end stop and reverses direction running at crawl speed.

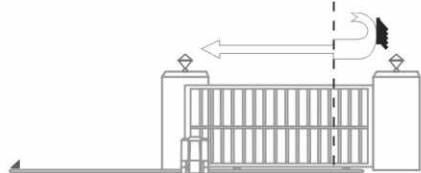

- 3** Gate hits "closed" end stop and reverses direction running at "FULL" speed until the Origin Marker passes the Origin Sensor, then at CRAWL speed to the end. (*See Setup troubleshooting Guide, page 34, step 10.3*)

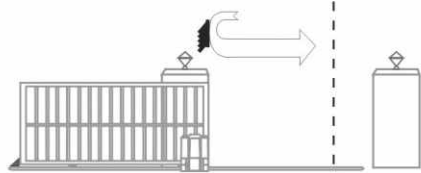

- 4** Gate hits "open" end stop and reverses but now runs at "FULL" speed.



- 5** As the gate Origin Marker passes the Origin Sensor the motor speed reduces to CRAWL. The gate hits the "closed" end stop and reverses at FULL SPEED.

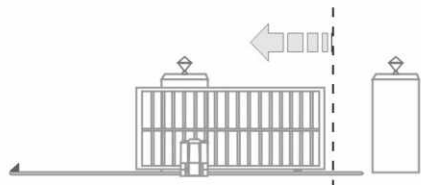

- 6** Gate stops at "pedestrian" (PED) position. (*See Setup troubleshooting Guide, page 32, step 10.6*)



For a faster setup, **press and hold the TEST** button during the automatic set-up routine. The speed will increase to FULL speed while the button is depressed, but be sure to not run the gate into the end stops at full speed.



After the Automatic Set-up Routine has been completed, the Pedestrian opening may be increased by momentarily pulsing the PED input to COM.

12. **Press and release the TEST** pushbutton once more to confirm the limits and pedestrian opening positions.

## Exit Programming Mode

13. Exit programming mode by **removing the SET link**. Store the link by pushing it over one of the two pins.

## Check Gate Operation

14. **Press and release the TEST** pushbutton to trigger the operator in order to confirm general operation of the gate. (🔧 See Setup Troubleshooting Guide, page 34, step 14 or the more complete Fault Finding Guide on page 35)

---

# Setting Additional Features

The default factory settings on the CP80 Controller have been selected to suit most applications. In many cases there would be no need to change the default settings. A list of features can be found on page 44, with a detailed description of each feature on page 29.

## Determine What Features are Required

15. Determine from page 44 what Features are required together with the relevant STATUS or COUNT value.

**Example:** "To turn the AUTO-CLOSE Feature ON": According to the Table the auto-close feature is Feature number 2, and to turn it ON is a status of 1.

## Get Into Programming Mode (Exactly the same as for limits setup)

16. **Remove ALL power** from the controller, i.e. charger plug and battery.
17. **Fit the SET link** to the SET pins as shown in figure 23 on page 25.
18. **Reapply power** by reconnecting the charger plug, and then the battery to the controller.

Immediately after reconnecting the power, the **STATUS light must flash 5 times**, and then SET and L2 will come on indicating that you are now in programming mode. (🔧 See Setup Troubleshooting Guide, page 33, step 18)

## Selecting the Feature to Change

(This is the first of two steps in setting a feature. This only **SELECTS** the feature to change).

19. To select the Feature to change, **Press and hold** the TEST button while monitoring LED L1.

---

STATUS light will start flashing at an even rate. Count all the flashes, and **release the TEST** button when the number of flashes is the same as the COUNT value required.

**Example 2:**

Set the AUTO-CLOSE TIME to 10 seconds (That is Feature number 3, to a COUNT value of 10):

First select the Feature number 3 as in steps 5 to 7. Then **press and hold** the TEST button while monitoring the STATUS light:

After a slight pause, the STATUS light will start flashing regularly:

Flash (1), Flash (2), Flash (3), Flash (4), Flash (5), Flash (6), .....Flash (9), Flash (10).

At this moment **release the TEST** button to give a COUNT value of 10. This sets the auto-close timer to 10 seconds.

L2 will come back on, indicating that the COUNT has been updated.

## Controller Programmable Features

The terminology "FEATURE 2-2" refers to Feature number 2 with a status of 2. "FEATURE 3- COUNT" refers to Feature number 3, with a user specified COUNT value.

### Auto-close

This can be programmed ON (FEATURE 2-1) or OFF (FEATURE 2-2). The factory default is OFF. Auto-close has the function of automatically closing a gate after a preset auto-close time.

A gate that is stopped while opening will always auto-close. A gate that is stopped while closing will remain where it is stopped indefinitely (applies to STANDARD mode of operation only)

The Auto-close time is set in FEATURE 3-COUNT. It can be set from 1 to 255 seconds

### Auto-close Override

It is possible for the user to temporarily turn off auto-close when the mode of operation is either STANDARD and REVERSING. This is done by applying an impulse to the TRG input at the time of opening the gate, for a period of time longer than the AUTO-CLOSE OVERRIDE TIME as set in FEATURE 8-COUNT.

To provide feedback that the override signal has operated, the gate will open and then stop opening after the override time. The instant the impulse is removed the gate will complete its opening cycle. The Auto-close feature is now off and the gate will remain open indefinitely. The next impulse received on TRG will initiate the closing cycle and the auto-close is automatically re-instated.

### Mode of Operation

It is possible to select 4 different modes of operation: STANDARD, CONDOMINIUM, PIRAC and REVERSING (FEATURE 4-1 to 4-4). Only one mode can be activated at any one time. All the modes are triggered by the contact present between the TRG input terminal and the COM terminal.

**STANDARD MODE** (FEATURE 4-1) (This is the factory default mode) - A trigger impulse will cause the gate to start moving (either open or closed depending on its position). A second impulse while the gate is still moving will stop the gate. A third impulse will cause the gate to reverse its direction of travel, i.e the action is START - STOP - REVERSE.

- 
20. L1 will flash once then go off, twice in short succession then go off, 3 times then go off, etc.  
**Release the TEST button** when the number of flashes is the same as the Feature number to select.

**Example 1:**

To set the MODE OF OPERATION to CONDOMINIUM (That is Feature number 4, to a status of 2 according to the table on page 43) **Press and hold** the TEST button while monitoring L1:

The L1 light will flash once and pause,

then flash twice and pause....

then flash 3 times and pause....

then flash 4 times and pause....

At this moment **release the TEST** button to select Feature 4. L2 will turn off, and L1 will keep on flashing 4 times and pausing to indicate that **Feature 4 is selected**

**NOTE: The STATUS of the Feature is not changed yet, the feature has only been selected to be changed!**



21. If an incorrect Feature is selected, then remove and re-apply power and re-start from step 3. None of the Feature settings will have been altered at this stage.

## Changing the STATUS or COUNT value of a Feature.

22. To set the **STATUS** value of the Auto Close, Mode of Operation, Collision Sensitivity, Positive Close mode or Pre-flashing features:

**Press and hold the TEST** button while monitoring the STATUS light. The STATUS light will flash the same as for selecting a Feature. (See Step 4) Release the TEST button when the number of flashes is the same as the STATUS value required.

**Example 1 (continued):**

To set the MODE OF OPERATION to CONDOMINIUM:

After selecting the Feature, again **press and hold** the TEST button while monitoring the STATUS light:

The L1 light will flash once and pause,

then flash twice and pause.....

At this moment **release the TEST** button to give a STATUS value of 2. The mode of operation has been changed to condominium.



**NOTE: Only after setting the STATUS, would the mode of operation be changed to CONDOMINIUM!**

L2 will come back on, indicating that the STATUS has been updated.

23. To set the **COUNT** value of the Auto-close timer, Pedestrian Auto-close time, Courtesy light timer, Auto-close override timer, Pre-flashing time or Collision counter features:

**Press and hold the TEST** button while monitoring the STATUS light. After a slight pause, the STATUS light will start flashing at an even rate. Count all the flashes, and **release the TEST** button

---

**CONDOMINIUM MODE (FEATURE 4-2)** - Any trigger will cause a gate, which is closed or closing to open or re-open. If not already active the auto-close will automatically be turned on when condominium mode is selected. It is only the auto-close signal, which can close a gate in condominium mode. If a trigger impulse is given while the gate is open the auto-close time is reset to its preset value.

**PIRAC MODE (FEATURE 4-3)** - An acronym for Passive Infra Red Auto Close, this mode operates similarly to condominium mode but instead of waiting for the auto-close timer to close the gate, it will close as soon as an object that has passed through the gate clears the infrared beam. If the beam is not broken the gate will get to its fully open position and close immediately when auto-close is turned OFF.

If the Auto-close feature is turned ON the gate will open and remain open for the set auto-close time, and then close. The gate will however close as soon as an object has passed through and cleared the beam, regardless of the Auto-close time.

**REVERSING MODE (FEATURE 4-4)**- This mode is similar to standard mode but instead of stopping a gate when it is in motion, a trigger will cause the gate to reverse its direction of travel. It is thus impossible to leave a gate stationary in a partly open position. The only two normally stable states are fully open or fully closed. If the auto-close is ON then the gate will always tend towards being closed.

### **Pedestrian Auto-Close Time (FEATURE 5-COUNT)**

A separate auto-close timer exists for the pedestrian opening. The time can be set from 1 to 255 seconds but cannot be turned off completely. The default time is 5 seconds.

### **Collision Sensitivity (FEATURE 7-1 to 7-3) (The factory default is 7-2)**

If the gate is obstructed the internal collision circuitry will activate. When the gate is opening, and it is obstructed the gate will stop. During closing however, an obstruction to the gate will cause it to immediately stop and reverse direction. There is a counter (FEATURE 12-COUNT) that monitors the number of collisions. If the collision count is reached before the gate reaches the fully closed position all trigger signals are inhibited for a 1-minute period. The STATUS LED flashing 4 times per second indicates this condition. After the one-minute period, triggers will again become active, (with the exception of auto-close). The fault indication will continue to flash indefinitely after the 1-minute period but will clear after the 1-minute period if a valid trigger is given. The collision counter resets to zero after the 1 minute delay, or if the processor is reset (e.g. By removing all power from the controller).

### **Courtesy (Pillar) Light:**

The pillar light circuit has multiple functions:

- It operates as a courtesy light and switches on for a timed period (The factory default time is 2 minutes) (set by FEATURE 6-COUNT) every time the gate triggers.
- It can be turned on for the preset timed period, by the application of a short impulse between the SET terminal and COM.
- It can be turned ON permanently by application of an impulse longer than 3 seconds on SET and COM terminals. A short impulse thereafter will switch the lights off. The gate will not trigger open when using the SET trigger. The fact that the pillar light is ON permanently is indicated by the STATUS LED flashing once every 2 seconds.
- When the PED input is triggered the pillar light flashes for an adjustable (1 to 255 seconds) pre-flash time (FEATURE 11-COUNT) before the pedestrian gate opens. (Default pre-flash time is 2 seconds).
- The contact can be used to operate a lamp, which will warn that the gate is about to open.

- 
- The contact can be used to operate a lamp, which will warn that the gate is about to open. Selection of pre-flashing is done in FEATURE 10. Three modes and OFF are selectable (The factory default is OFF):
    - Mode 1 - Light comes on only while gate is in motion.
    - Mode 2 - Light flashes at 1Hz for the pre-flash time and then flashes in synchronism with the STATUS LED while the gate is in motion.
    - Mode 3 - Light comes on for the pre-flash time and while the gate is in motion.

### Positive Close Mode:

Setting positive close mode to ON (FEATURE 9-1) (default is OFF, FEATURE 9-2) will allow the gate to drive up hard to an end stop without causing the collision circuitry to operate. This Feature operates only during the final crawl phase in the closing direction.

### Crawl Distance:

The Crawl Distance is the distance allowed for the gate to slow down before reaching either the open or closed limits. Under certain conditions the Crawl Distance may not need to be increased to prevent hitting the end stops

## Controller Terminal Features

COM	The battery/power supply negative terminal. All trigger signals etc. have their return path to one of the COM terminals.
LIGHT	These two terminals provide a normally open potential free contact which is generally used to switch on a pillar light (courtesy light). It can also be used for other purposes if required.
12V	Provides a +12V DC supply for auxiliary equipment such as a radio receiver, photo cells etc. It is linked directly to the battery positive via the 3A fast-blow auxiliary fuse (see page 41).
TRG	A momentary, normally-open trigger device such as relay, pushbutton etc. connected between TRG and COM will cause the gate to trigger open/closed. Connect multiple trigger devices in parallel (Refer to page 41).
IRB	The signal from the infra red beam (IRB)(photo cell), safety edge, loop or other safety device. This prevents the gate from closing when the normally-closed contact between IRB and COM is open. For multiple safety devices wire all contacts in series.   <b>NB:</b> If no safety devices are fitted ensure a wire link is fitted between IRB and COM.
FRX	A momentary normally-open contact from a device such as a free exit inductive loop detector (or photo cell or pushbutton) which causes a gate which is closed or closing to open or re-open. If the gate is open or opening the signal has no effect other than to reset the auto-close timer (if selected). Free exit (FRX) will never initiate a closing cycle. If only the FRX input is used, the auto-close must be turned on alternatively the TRG input used to close the gate.
LED	An output terminal which provides a low current, (approx. 4,5V DC, 20mA) to drive an LED which can be used to indicate the gate status remotely. If more than 3 LED's are required it is necessary to fit a multi LED driver card (CP78).

---

PED	A momentary normally-open contact from a pedestrian key switch, pushbutton, keypad, radio receiver etc. which will cause the gate to open to the Pedestrian position. The gate opens only after the adjustable pre-flash time (default - 2 seconds). If the contact is held closed the auto-close is suspended until the contact reopens.
LCK	<p>If the normally-closed contact between LCK and COM is held open, all triggers which would normally cause a closed gate to open (e.g. TRG, PED, FRX) will be inhibited. If the gate is open, opening or closing and the LCK contact is opened the gate will continue to respond until such time as the gate is in the fully closed position.</p> <p> <b>NB:</b> If the LCK function is not required a link must be fitted between LCK and COM. For operators fitted with a CE chip, LCK is configured as an opening safety beam input and operates in the same manner as the IRB input except that the gate would stop and reverse when opening and stop when closing.</p>
SET	<p>This terminal has two functions:</p> <ol style="list-style-type: none"><li>1. If SET is linked to COM with no power present to the controller and power is then applied, the controller will be put into Programming mode.</li><li>2. If SET is linked to COM when power is already applied, this action will cause the pillar light relay to energise. A momentary contact causes the relay to energise for a period of time as defined for the courtesy light timer. If the contact is made for a period exceeding 3 seconds the pillar light relay will energise and remain energized indefinitely until a new momentary contact is given.</li></ol>

## Procedure to Programme Controller Back to Factory Default Settings

---

1. Remove all power (Power supply and battery).
2. Fit the "SET" link.
3. Connect "PED" and "FRX" to "COM".
4. Reconnect all power. (L1 AND L2 will illuminate).
5. Remove all power (Battery and power supply).
6. Remove the "SET" link and disconnect "PED" and "FRX" from "COM".
7. The card is now programmed to default settings as shown on page 44 (Gate open/closed limits are not affected).



# Set-up Troubleshooting Guide

SET-UP STEP	PROBLEM	POSSIBLE CAUSES & SOLUTIONS TO PROBLEM
4 or 18	<p>SET light is not on:</p> <p>L2 is not on:</p> <p>STATUS light did not flash 5 times:</p> <p>L1 is flashing:</p>	<p>Check that the SET link is correctly fitted. Fit and remove the link a few times to ensure good contact, restart from step 2.</p> <p>All sources of power on the card must be removed. Check by confirming that all the lights turn off, before reconnecting the power with the set link fitted, restart from step 2.</p> <p>The controller did not “boot-up” correctly. Try to fit the charger plug before reconnecting the battery, restart from step 2.</p> <p>Check for and remove latching inputs on the TRG terminal then restart from step 2 on page 24.</p>
10	<p>There is a short click but the <b>motor does not turn</b>. The STATUS light flashes L2 turns on.</p> <p>There is a click, the motor turns but the <b>gate does not move</b>.</p> <p>Three consecutive slow relay clicks but <b>motor does not move</b>.</p> <p>Motor makes three short opposing movements on gate, L2 comes on.</p>	<ul style="list-style-type: none"> <li>• Check for loose connections or corrosion on battery terminals.</li> <li>• If an external battery is used, check that the battery cables are not too thin. They must be no less than 4mm<sup>2</sup></li> <li>• Check for low battery condition by following procedure A on page 37.</li> <li>• Correct the problem, remove and refit the SET link and start from step 8 on page 24.</li> </ul> <p>The manual release mechanism is still in manual mode, restart from step 6.</p> <ul style="list-style-type: none"> <li>• The motor not being connected to the controller, or</li> <li>• The motor fuse could be blown, or</li> <li>• The motor is faulty. Check motor by connecting motor leads directly to the battery.</li> <li>• The DOSS sensor system is faulty.</li> <li>• Is the DOSS harness plugged in? If so, there could be a fault on the sensor, cable or controller.</li> <li>• Is there any water or oil present in the DOSS sensor area? Correct the problem as restart from step 5</li> </ul>
10.2	Gate is fully open and does not return to complete the Automatic Setup Routine. L2 and L1 are off.	<ul style="list-style-type: none"> <li>• Battery capacity too low to complete setup.</li> </ul>
10.3	Gate runs full speed into endstop.	<ul style="list-style-type: none"> <li>• Gate origin marker not present. See page 22 for fitting instructions.</li> </ul>

10.6	<p>Gate does not open to pedestrian opening.</p> <p>Gate does not stop at pedestrian but continues all the way to the open end stop.</p>	<ul style="list-style-type: none"> <li>• Origin marker not positioned correctly. (See Figure 19)</li> <li>• Continuous trigger on PED input.</li> <li>• Origin Marker not positioned correctly.</li> </ul>
12	Gate hits closed end stop, but does not re-open	Is the magnetic sensor switch functioning correctly? Ensure the gate magnet passes as close as possible to the sensor. See page 23.
14	<p>Gate hits the endstop.</p> <p>The gate does not move, STATUS light flashes 5 times and L2 turns on.</p> <p>The gate stopped short of either the open or closed position:</p> <p>The gate does not close when pressing TEST:</p>	<p>With the CE chip installed the crawl distance is much longer. Check that the origin marker is correctly positioned as shown on page 23.</p> <ul style="list-style-type: none"> <li>• Check that the set link has been removed.</li> <li>• Check if the LCK &amp; IRB LED's are on.</li> <li>• Check if the FRX LED is off.</li> <li>• The gate limits were not set correctly. Restart from step 6 on page 24.</li> <li>• The gate dynamics could be detected as a collision by the controller. Set the gate collision sensitivity to be less sensitive (feature 7 to setting 2 or 3) (See page 44)</li> <li>• Mode of operation could be set to condominium, which only allows the gate to be closed by the auto-close timer.</li> <li>• The safety beams or holiday lockout features could be activated. Check the IRB and LCK lights, both must be ON for normal operation.</li> <li>• The link between COMMON and LCK might not be fitted, when the safety lockout feature is not used.</li> <li>• The link between COMMON and IRB might not be fitted, when safety beams are not used.</li> </ul>

# Fault Finding Guide

PROBLEM	POSSIBLE CAUSES & SOLUTIONS TO PROBLEM
1 Gate does not move:	<ul style="list-style-type: none"> <li>• Check that you are <b>out of programming mode</b>, SET light must be OFF.</li> <li>• <b>LCK (lockout) input activated</b>. Green LCK light should be ON.</li> <li>• <b>IRB (IR beams) input activated (Gate will not close once open)</b>. Green IRB light should be ON. Check cabling, and 12V power (3A auxiliary fuse).</li> <li>• <b>Latching input on TRG or FRX</b>. (Both TRG and FRX lights must be off for gate to operate.)</li> <li>• Check the battery condition with procedure <b>A: Low battery voltage condition</b>, later in this section.</li> <li>• If STATUS light flashes 4 times then the operator is in <b>Multiple Collision Mode</b>. Remove &amp; reapply all power, or wait 60 seconds to reset operation. If required, check with procedure <b>B: False collision detection</b>, later in this section.</li> <li>• If the problem persists, the <b>CP80</b> main controller might be faulty.</li> </ul>
2 Gate does not move, but the relays "click" for +/- 2 seconds when the unit is activated:	<ul style="list-style-type: none"> <li>• Motor brushes could be faulty.</li> <li>• Check the motor wires.</li> <li>• Check 16A fuse and connections.</li> <li>• If STATUS light flashes 4 times then the operator is in <b>Multiple Collision Mode</b>. Check for and remove possible obstructions. Remove &amp; reapply all power, or wait 60 seconds to reset operation. If required, check with procedure <b>B: False collision detection</b>, later in this section.</li> </ul>
3 Gate does not move, but the relays "click" and drop out immediately.	<ul style="list-style-type: none"> <li>• Faulty battery. Check the battery condition with procedure <b>A: Low battery voltage condition</b>, especially if the STATUS light flashes 3 times.</li> <li>• If the problem persists, the <b>CP80</b> main controller might be faulty.</li> </ul>
4 Gate moves a short distance and stops:	<ul style="list-style-type: none"> <li>• Check the battery condition with procedure <b>A: Low battery voltage condition</b>, especially if the STATUS light flashes 3 times.</li> </ul>

PROBLEM	POSSIBLE CAUSES & SOLUTIONS TO PROBLEM
<p>5 Gate moves a short distance and stops:</p>	<ul style="list-style-type: none"> <li>• Check for false collisions with procedure <b>B: False collision detection</b>, later in this section (STATUS light could also flash 4 times if the number of detected collisions exceeded the COLLISION COUNTER feature value).</li> <li>• Intermittent IRB trigger only on closing cycle. Check that the voltage applied to the beams is appropriate.</li> <li>• Spurious trigger. Remote with same coding operated in area, or intermittent short due to possible moisture on the FRX or TRG inputs. Monitor FRX or TRG LED's.</li> <li>• If the problem is still not solved, the CP80 main controller might be faulty.</li> </ul>
<p>6 Gate starts closing then stops &amp; reopens:</p>	<ul style="list-style-type: none"> <li>• Check collision sensitivity and other causes with procedure <b>B: False collision detection</b>.</li> </ul>
<p>7 Gate overruns its limits:</p>	<ul style="list-style-type: none"> <li>• Check that the origin marker is correctly positioned as shown on page 23.</li> <li>• Check that the ORIGIN sensor wire <b>harness is securely plugged</b> into the CP80 control card, the DOSS sensor assembly and the magnetic switch assembly (see items 2 and 21 on page 12)</li> <li>• Check that the respective <b>ORIGIN sensor is securely clipped</b> into the housing.</li> <li>• Check if the gate <b>origin was accidentally moved</b>, steps 4 to 10 of the electrical setup. If so reset the limits.</li> <li>• If the problem is not solved, the <b>CP80</b> main controller might be faulty.</li> </ul>
<p>8 Unreliable auto-close</p>	<ul style="list-style-type: none"> <li>• <b>Latching Receiver on TRG</b>, would activate the auto-close override feature.</li> <li>• <b>Long pulse on TRG</b> would activate the auto-close override feature.</li> <li>• <b>Faulty IR Beam</b> signal.</li> <li>• <b>Intermittent power loss</b>, check for low voltages with procedure <b>A: Low battery voltage condition</b>.</li> <li>• If the problem is still not solved, the <b>CP80</b> main controller might be faulty.</li> </ul>

Fault Finding Guide Continued...

PROBLEM	POSSIBLE CAUSES & SOLUTIONS TO PROBLEM
9 Gate opens to pedestrian and closes	<ul style="list-style-type: none"> <li>• <b>Intermittent fault</b> on PED (pedestrian) input. Check wiring, and key switch operation. <b>B: False collision detection.</b></li> <li>• If the problem is still not solved, the <b>CP80</b> main controller might be faulty.</li> </ul>
10 Gate takes a few seconds before it opens to pedestrian	<ul style="list-style-type: none"> <li>• By default the motor would delay opening to pedestrian for 2 seconds. This time can be changed by altering the value of the PREFLASH TIME feature (FEATURE 11) (Minimum time is 1 second).</li> </ul>
11 Gate opens to pedestrian & stays there	<ul style="list-style-type: none"> <li>• <b>There is a continuous PED signal</b>, the PED light will be on continuously. (The PED light &amp; signal must turn on momentarily for the gate to close after a pedestrian signal.) Check for latching Receiver, or a faulty key switch.</li> <li>• If the problem is still not solved, the <b>CP80</b> main controller might be faulty.</li> </ul>
12 Gate stuck in the Open position	<ul style="list-style-type: none"> <li>• <b>There is a continuous FRX,TRG signal</b>, the FRX, TRG light will be on continuously. (The TRG, FRX light &amp; signal must turn on momentarily for the gate to operate normally.)</li> <li>• If the problem is still not solved, the <b>CP80</b> main controller might be faulty.</li> </ul>
13 Gate opens from the intercom but not from the receiver	<p>The fault is with the receiver.</p> <ul style="list-style-type: none"> <li>• <b>Check the wiring</b> between the receiver and control card.</li> <li>• Check that the <b>receiver has power</b>. If not, check the 3A Auxiliary fuse on the main controller. (NB. remove fuse before measuring.)</li> <li>• The receiver could be faulty.</li> <li>• Check remotes are learned correctly to receiver.</li> </ul>
A <b>Low Battery Voltage Condition</b> ( <b>STATUS light flashes 3 times</b> )	<p>If the battery voltage is less than 10.5V, the motor would not operate at all. For any other voltage, the battery could still be the cause of the problem.</p> <ul style="list-style-type: none"> <li>• Check that the <b>power is turned ON</b>, by first disconnecting the battery and then to check that the green CHARGE light is ON. If it is OFF, then check the power supply fuse (CP84E 250mA) (PSU 6 1A). If the fuse is fine, power is not connected to the charger or the power pack.</li> </ul>

PROBLEM	POSSIBLE CAUSES & SOLUTIONS TO PROBLEM
<p><b>Low Battery Voltage Condition</b> (STATUS light flashes 3 times) (Continued)</p>	<ul style="list-style-type: none"> <li>• Check the <b>condition of the battery leads</b>, terminals and connectors. Look for and correct all loose connections and signs of corrosion.</li> <li>• <b>The battery might be discharged.</b> Measure the battery voltage with the charger connected, if the voltage is below 12.5V then the battery is discharged. The number of opening cycles per hour may be excessive, thus discharging the battery. Charge the battery, or fit a 10A power pack with CP80 PSU) if required.</li> <li>• <b>Charger might be faulty.</b> Disconnect the battery, and measure the voltage on the battery leads. It must be between 13.6V and 13.8V, if not replace the charger.</li> <li>• <b>Battery might be old</b>, and might have to be replaced. If in doubt test as follows:             <ul style="list-style-type: none"> <li>◦ Check that the <b>battery is charged</b>, by ensuring that the battery voltage is above 13.5V with the charger connected. (If the battery is in a good condition it would probably pass the test without being fully charged)</li> <li>◦ <b>Disconnect the charger</b> from the battery</li> <li>◦ <b>Remove the DC Motor leads</b> from the DC Controller</li> <li>◦ Apply the DC motor leads <b>directly to the battery</b>, while measuring the battery voltage. WARNING: First make sure that the moving gate will not pose any danger.</li> <li>◦ If the <b>gate does not move, the battery or motor could be faulty.</b></li> <li>◦ If the <b>battery voltage remains unchanged</b>, then the motor is faulty and must be serviced. If the battery <b>voltage drops to below 11,2V</b> then the battery must be replaced.</li> </ul> </li> </ul> <p>(Before replacing the battery, measure the charging voltage on the battery leads with the battery disconnected. It must be between 13.6V and 13.8V, if not, replace the charger.)</p>
<p><b>B False Collision Detection</b> (STATUS light flashes 4 times to indicate that number of collisions have exceeded COLLISION COUNTER feature value. Wait 60 seconds, or remove &amp; reapply all power to reset operation.)</p>	<ul style="list-style-type: none"> <li>• Check for badly running gate, or something <b>physically obstructing the gate</b>. Activate the manual override and manually move the gate to check for ease of operation.</li> <li>• Check for ants, dirt, oil or water in and around the DOSS sensor.</li> <li>• Check the <b>DC motor wires for loose connections.</b></li> <li>• Check <b>contact of the fuses</b> with the fuse holder on CP80 (main controller). The fuse must tightly snap into place.</li> </ul>

<b>PROBLEM</b>	<b>POSSIBLE CAUSES &amp; SOLUTIONS TO PROBLEM</b>
<b>False Collision Detection (STATUS light could flash 4 times to indicate that number of collisions have exceeded COLLISION COUNTER feature value. Wait 60 seconds, or remove &amp; reapply all power to reset operation.) (Continued)</b>	<ul style="list-style-type: none"><li>• Check that the sensor wire <b><i>harness is securely plugged into</i></b> the CP80 (master controller) into the DOSS sensor.</li><li>• Check that the <b><i>DOSS sensor</i></b> is securely clipped into the housing.</li><li>• If the problem is not solved replace the DOSS sensor and main controller (CP80).</li></ul> <p><b>Note:</b> Red/Black/Orange Wire = Origin Switch and Red/Black/Purple Wire = DOSS Sensor</p>

# CP80 Power Connections

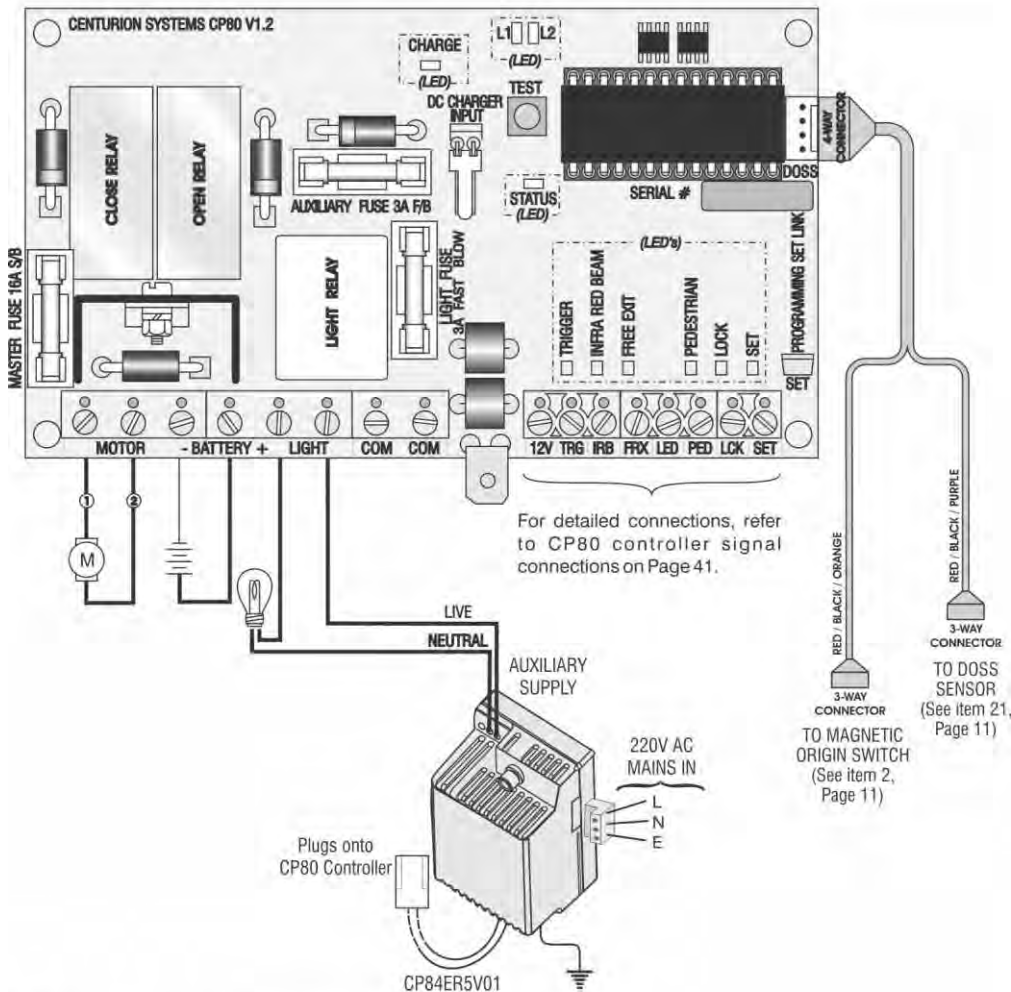

When setting the gate limits during the commissioning procedure as described on Page 24, it may be necessary to change the motor direction.

To change the master motor direction swop wires (1) and (2).



# CP80 Signal Connections

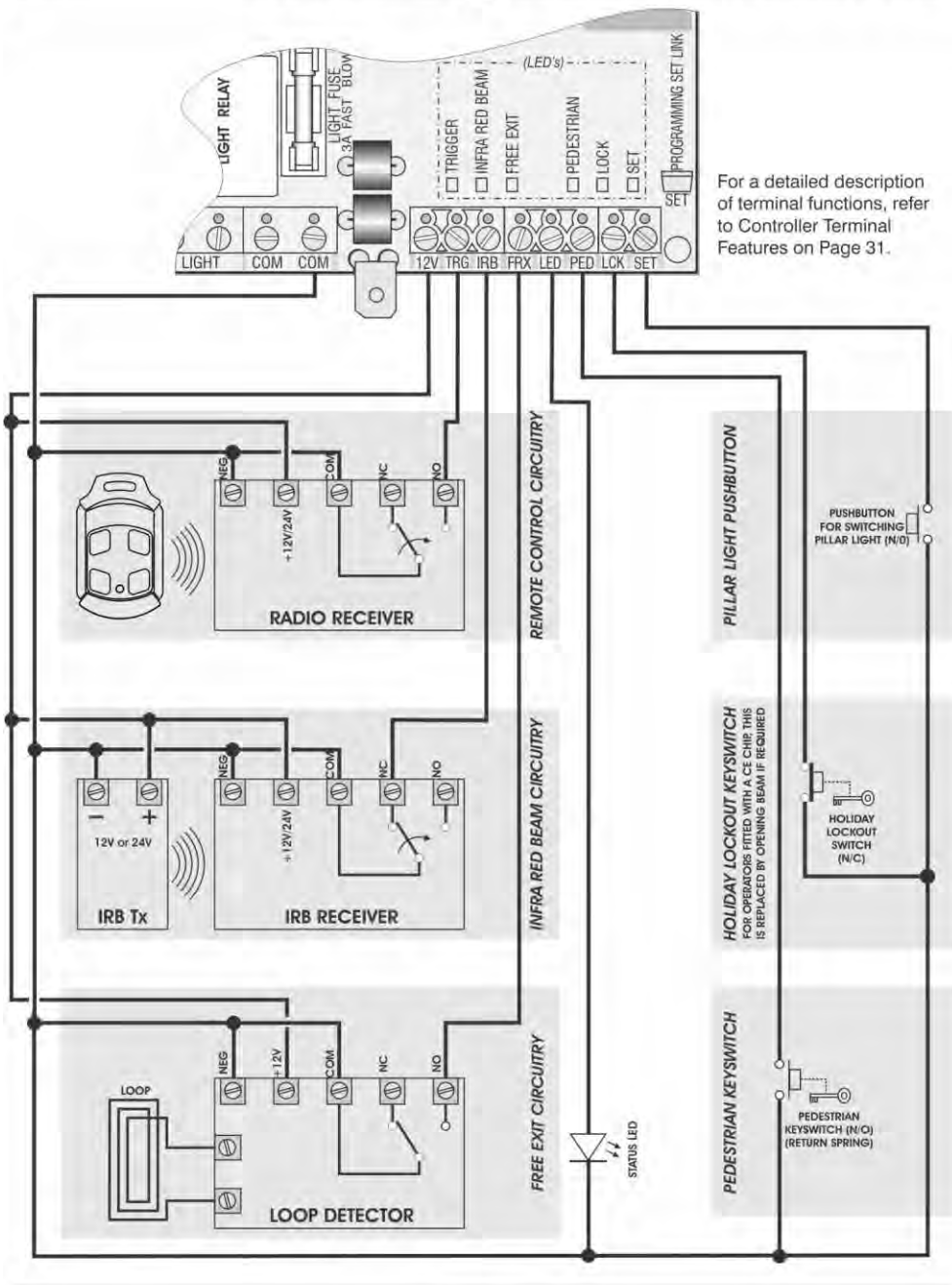

For a detailed description of terminal functions of terminal functions, refer to Controller Terminal Features on Page 31.

# CP84E Charger Connection

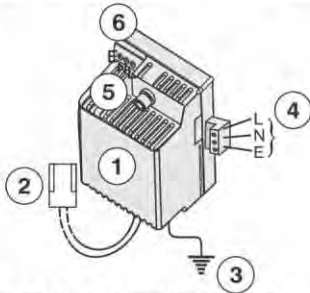

- 1 CP84E Charger Transformer
- 2 14.2V DC charger plug to CP80 controller
- 3 Lightning Earth Point
- 4 220V AC, 1Ø, Mains Supply for CP84E using removable connectors
- 5 Mains fuse (250mA Slow-blow (T), size 5 x 20mm)
- 6 Auxiliary Mains Connector, 220V AC

# CP84XTE Charger Connection

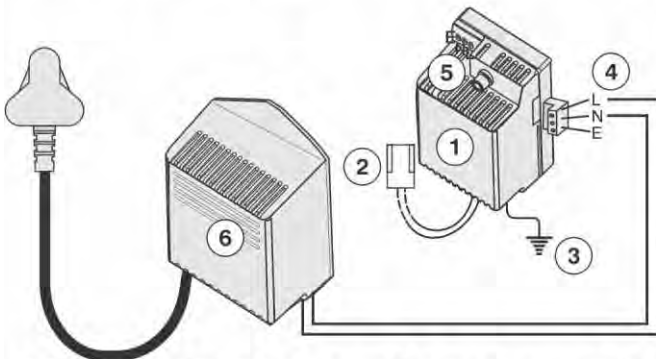

- 1 CP84XTE Charger Transformer
- 2 14.2V DC charger plug to CP80 controller
- 3 Lightning Earth Point
- 4 19V AC, 1Ø, Supply for CP84XTE
- 5 Fuse (250mA Slow-blow (T), size 5 x 20mm)
- 6 CP53 Power supply

# PSUx Power Connection

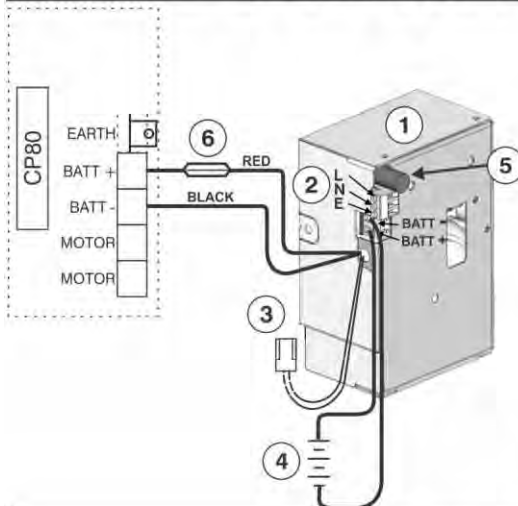

- 1 PSUx - Power Supply Unit
- 2 220V AC, 1Ø, Mains Supply for CP84E using removable connectors
- 3 DC charger plug to CP80 controller
- 4 12V DC lead acid battery (Amp/hour rating to suit)
- 5 Mains Fuse - 1A Slow-blow (T) size (5x20mm)
- 6 20A Slow-blow fuse

For PSU operated D3 or D5 operators, use a CP80PSU controller or a modified equivalent.

# Recommended Earthing for Effective Lightning Protection

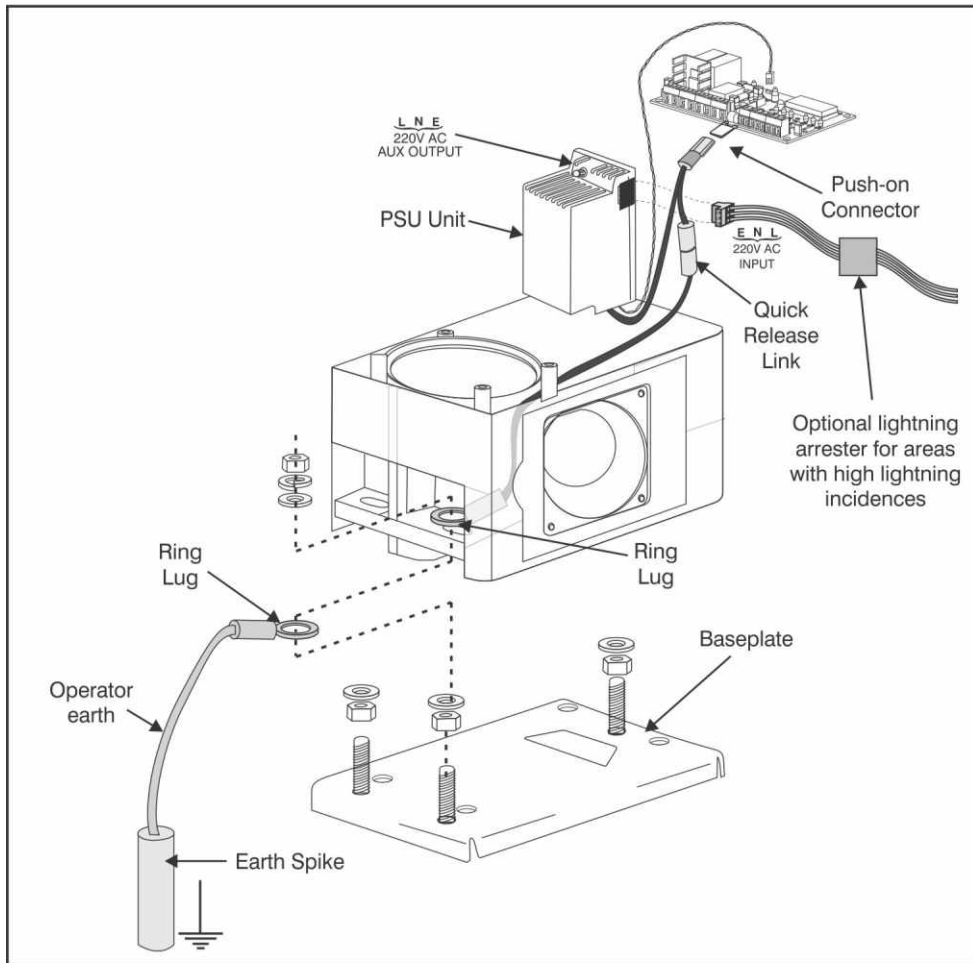

Figure 25 Lightning Protection Connections

1. For optimum lightning protection ensure earth cable from charger/PSU unit is adequately earthed to a separate earth spike.
2. Use ring lug to bond to baseplate mounting stud.
3. For additional protection bond baseplate to earth spike.
4. In event of damage to charger/PSU unit disconnect quick release link and push-on connector on controller.
5. In areas with a high incidence of lightning it is recommended to add an additional high current arrester on the mains input (1) before the charger. Ensure the earth of the surge arrester is securely bonded to the operator earth.

# CP80 Controller Features

FEATURE		STATUS or COUNT		
DESCRIPTION	FEATURE NUMBER	STATUS VALUE	COUNT VALUE	DESCRIPTION
Gate Limit Settings	1	-	-	See detailed instructions on page 25
Auto-close	2	1	-	ON
		2	-	OFF (Default)
Auto-close Time	3	-	1 Flash = 1 second	15 seconds (Default)
Mode of Operation	4	1	-	STANDARD (Default)
		2	-	CONDOMINIUM
		3	-	PIRAC
		4	-	REVERSING
Pedestrian Auto-close	5	-	1 Flash = 1 second	5 seconds (Default)
Courtesy Light	6	-	1 Flash = 10 seconds	120 seconds (Default)
Collision Sensitivity*	7	1	-	HIGH*
		2	-	MEDIUM (Default)*
		3	-	LOW
Auto-close Override	8	-	1 Flash = 1 second	3 second (Default)
Positive Close Mode	9	1	-	ON
		2	-	OFF (Default)
Preflashing	10	1	-	MODE 1
		2	-	MODE 2
		3	-	MODE 3
		4	-	OFF (Default)
Preflash Time	11	-	1 Flash = 1 second	5 seconds (Default)
Collision Counter	12	-	1 Flash = 1 count	4 counts (Default)
Crawl distance †	13	-	1 Flash = 350mm	1 Count = 350mm

† The crawl distance is a length of travel which allows the gate to slow down before reaching the end stop. For heavier gates with less friction, the crawl distance may have to be increased. When increasing the crawl distance, the origin marker (Figure 19) must be moved and the gate limits reset as in step 6, page 24.  
Where operators have been fitted with a CE chip, the crawl distance value is fixed to a count of 2.

 \* For CE compliance use a collision sensitivity value of 1 or 2 only

	CRAWL DISTANCE†	STATUS FLASH COUNT	DISTANCE BETWEEN MARKER AND PINION
DEFAULT	350mm	1	500mm
	700mm	2	750mm
	1050mm	3	1100mm



To speed up the counting while selecting main menu items, temporarily connect the PED terminal to the COM terminal.

# LED Indicator Lights

The controller is fitted with diagnostic LED's (Light Emitting Diodes) that assist with the set-up and maintenance of the gate. Table 3 provides a description and purpose of the indicator LED's. See page 40 for location.

NAME	COLOUR	ON	OFF	REMARKS
TRG	Red	Signal present	No signal	N/A
IRB	Green	Safeties clear	Safeties obstructed	N/A
FRX	Red	Signal present	No signal	N/A
PED	Red	Signal present	No signal	N/A
LCK	Green	System ready to operate	System locked	N/A
SET	Red	Signal present	No signal	N/A
STATUS (During normal operation)	Red	Gate fully open	Gate fully closed	Off - Gate is closed. Slow continuous flash - Gate is opening. On - Gate is open. Fast continuous flash - Gate is closing. 1 Flash/sec - Pillar light on permanently. 2 Flashes/sec - No mains. 3 Flashes/sec - Battery low detection. 4 Flashes/sec - Collision detector operated. 5 Flashes/sec - Microprocessor reset.
STATUS (During programme mode)	Red			The number of flashes correspond to the STATUS or COUNT value being set.
L1 (During normal operation)	Red			Origin diagnostic (Changes state to indicate origin status) Off when gate is on "CLOSED" side. On when gate is on "OPEN" side.
L1 (During programme mode)	Red	If LED2 also on, system reset to factory default.		The number of flashes corresponds with the FEATURE number being selected
L2 (During normal operation)	Red			DOSS diagnostic (Changes state to indicate DOSS pulses)
L2 (During programme mode)	Red	System in programme mode. If L1 also on, system reset to factory default.		
CHARGER ON	Green	Battery charging	No charge voltage present.	

Table3 LED Indicator Light Description & Purpose

# Installation Handover

---

Once the installation has been successfully completed and tested, it is important for the installer to explain the operation and safety requirements of the system.

**NEVER ASSUME THE USER KNOWS HOW TO SAFELY OPERATE AN AUTOMATED GATE.** Even if the user has used one before, it does not mean he knows how to **SAFELY** operate it. Make sure that the user fully understands the following safety requirements before finally handing over the site.

Ensure that the user fully understands:

- How to operate the manual release mechanism. (By demonstration)
- How the obstruction detection and all other safety features work. (By demonstration)
- All the safety considerations associated with operating an automated gate, and that he understands that he is responsible for explaining these safety instructions to all other users of the automated system:
  1. Do not activate your gate opener unless you can see it and can determine that its area of travel is clear of people pets, or other obstructions.
  2. **NO ONE MAY CROSS THE PATH OF A MOVING GATE.** Always keep people and objects away from the gate and its area of travel.
  3. **NEVER LET CHILDREN OPERATE OR PLAY WITH THE GATE CONTROLS,** and do not allow children or pets near the gate area.
  4. Be careful with moving parts and avoid close proximity to areas where fingers or hands could be pinched.
  5. Secure all easily accessed gate opener controls in order to prevent unauthorized use of the gate.
  6. Keep the automated gate system properly maintained, and ensure that all working areas are free of debris and other effects that could affect the gate operation and safety.
  7. On a monthly basis, check the obstruction detection system and safety devices for correct operation.
  8. All repair, and service work to this product must be done by a suitably qualified person.
  9. This product was designed and built strictly for the use indicated in this documentation. Any other use, not expressly indicated here, could compromise the good condition/operation of the product an/or be a source of danger.
  10. Centurion Systems (Pty) Ltd does not accept any liability caused by improper use of the product, or for use other than that for which the automated system was intended.
  11. Ensure that the customer is in possession of the User Guide and also complete the installation details in the back of the User Guide.

---

## **Installation Details**

Installation Date: .....

Installer's Name: .....

Installer's Address: .....

Installer's Telephone Number: ..... Installation Checked By: .....



**Sharecall 0860-CENTURION (0860 236 887)**  
**Head Office: +27 11 699 2400**

**Sharecall Technical Support 0861 003 123 or**  
**+27 11 699 2481**  
from 07h00 to 18h00 (GMT+2)

(Sharecall numbers applicable when dialed from within South Africa only)



0.07.A.0115\_22072013

**[www.centsys.com](http://www.centsys.com)**